

VESTA

Makes life comfortable

SERVICE & OPERATING MANUAL

AIR OPERATED DOUBLE DIAPHRAGM PUMP

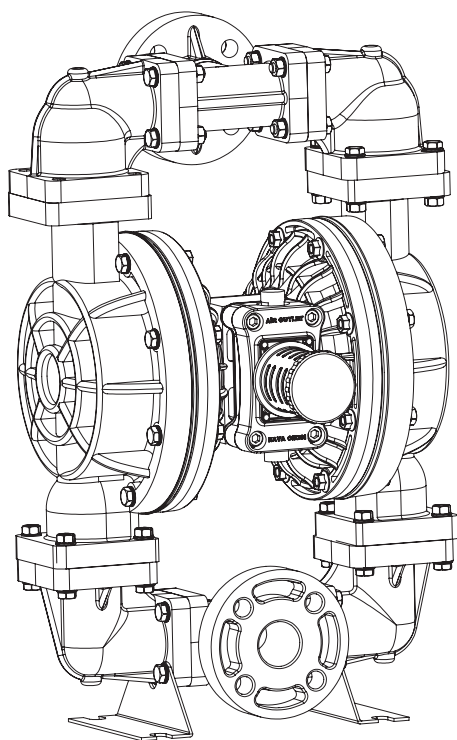

VP15

Алматы (7273)495-231
Ангарск (3955)60-70-56
Архангельск (8182)63-90-72
Астрахань (8512)99-46-04
Барнаул (3852)73-04-60
Белгород (4722)40-23-64
Благовещенск (4162)22-76-07
Брянск (4832)59-03-52
Владивосток (423)249-28-31
Владикавказ (8672)28-90-48
Владимир (4922)49-43-18
Волгоград (844)278-03-48
Вологда (8172)26-41-59
Воронеж (473)204-51-73
Екатеринбург (343)384-55-89
Россия +7(495)268-04-70

Иваново (4932)77-34-06
Ижевск (3412)26-03-58
Иркутск (395)279-98-46
Казань (843)206-01-48
Калининград (4012)72-03-81
Калуга (4842)92-23-67
Кемерово (3842)65-04-62
Киров (8332)68-02-04
Коломна (4966)23-41-49
Кострома (4942)77-07-48
Краснодар (861)203-40-90
Красноярск (391)204-63-61
Курск (4712)77-13-04
Курган (3522)50-90-47
Липецк (4742)52-20-81
Казахстан +7(7172)727-132

Магнитогорск (3519)55-03-13
Москва (495)268-04-70
Мурманск (8152)59-64-93
Набережные Челны (8552)20-53-41
Нижний Новгород (831)429-08-12
Новокузнецк (3843)20-46-81
Ноябрьск (3496)41-32-12
Новосибирск (383)227-86-73
Омск (3812)21-46-40
Орел (4862)44-53-42
Оренбург (3532)37-68-04
Пенза (8412)22-31-16
Петрозаводск (8142)55-98-37
Псков (8112)59-10-37
Пермь (342)205-81-47
Киргизия +996(312)96-26-47

Ростов-на-Дону (863)308-18-15
Рязань (4912)46-61-64
Самара (846)206-03-16
Саранск (8342)22-96-24
Санкт-Петербург (812)309-46-40
Саратов (845)249-38-78
Севастополь (8692)22-31-93
Симферополь (3652)67-13-56
Смоленск (4812)29-41-54
Сочи (862)225-72-31
Ставрополь (8652)20-65-13
Сургут (3462)77-98-35
Сыктывкар (8212)25-95-17
Тамбов (4752)50-40-97
Тверь (4822)63-31-35

Тольятти (8482)63-91-07
Томск (3822)98-41-53
Тула (4872)33-79-87
Тюмень (3452)66-21-18
Ульяновск (8422)24-23-59
Улан-Удэ (3012)59-97-51
Уфа (347)229-48-12
Хабаровск (4212)92-98-04
Чебоксары (8352)28-53-07
Челябинск (351)202-03-61
Череповец (8202)49-02-64
Чита (3022)38-34-83
Якутск (4112)23-90-97
Ярославль (4852)69-52-93

VESTA

Makes life comfortable

03.2018

Index

1 - Attention Symbols and Warnings

- 1.1 - Attention Symbol
- 1.2 - Warnings
 - 1.2.1 - Equipment Misuse Hazard
 - 1.2.2 - Toxic Fluid Hazard
 - 1.2.3 - Fire and Explosive Hazard

2 - Installation

- 2.1 - General Information
 - 2.1.1 - Safe Working Temperature for Body
 - 2.1.2 - Safe Working Temperature for Elastomer Parts
- 2.2 - Air Line
- 2.3 - Suction Line
- 2.4 - Compression Line
- 2.5 - Relief Valve for Fluid Pressure
- 2.6 - Outlet Air Discharge
- 2.7 - Grounding
- 2.8 - Washing and Cleaning the Pump
- 2.9 - Commissioning of the Pump
- 2.10 - Pressure Equipment Relief

3 - Operation

- 3.1 - Technical Information
 - 3.1.1 - Performance Curve and Pump Figure
 - 3.1.2 - Pump Type Coding
 - 3.1.3 - Spare Part Type Coding
 - 3.1.4 - Technical Specifications of the Pump
 - 3.1.5 - Pump Scaling
 - 3.1.6 - Packaging Sizes and Weights
 - 3.1.7 - Spare Parts Drawing (Metallic Body)
 - 3.1.8 - Spare Parts Drawing (Plastic Body)

4 - Maintenance

- 4.1 - Diaphragm Maintenance
 - 4.1.1 - Removal of Diaphragms
 - 4.1.2 - Installation of the diaphragm
 - 4.1.3 - Installation of the Diaphragms to the Pump
- 4.2 - Air Valve Kit Types and Maintenance
- 4.3 - Pilot Valve Repair Kit Types and Maintenance
- 4.4 - Actuator Plunger Maintenance
- 4.5 - Plastic and Metallic Body Pump Check Valve Maintenance
- 4.6 - Problems That May Occur in the Pump and their Solutions
- 4.7 - Torque Line in Plastic Body Pumps
- 4.8 - Torque Line in Aluminium Body Pumps

5 - Terms of Warranty

1-Attention Symbol and Warnings

1.1-Attention Symbol

Warning sign is the ATTENTION letter and symbol next to it. Severe accidents and injuries may occur if the instructions and rules implied by this symbol are not complied with. It can even cause death in the result of severe accidents. The user **MUST** read the warnings marked with this symbol, and act accordingly. Acting in accordance with these warnings can save your life and minimize the risk of injury.



CAUTION

1.2 –Warnings

The Operation Manual provides useful information on every stage of service life of the pump including operation, installation, repair and maintenance. The Operation Manual aims at providing you with the information on features, working principle and safety of the pump. This manual also contains maintenance instructions designed to improve safe operation of the pump. It is recommended to have all service and maintenance operations of the pump carried out by the authorized technical service of VESTAPOMP. VESTAPOMP service shall also provide other assistances and maintenance that may be needed in addition to its superior service and maintenance. This Operation Manual shall be considered as an integral part of the pump, and it shall be kept an accessible place to be referred when necessary. Noncompliance with these warnings can cause material damages to the pump and the pump equipment.



CAUTION *Operation Manual specifies instructions for operation of the diaphragm pump, and the user must read this manual before using the pump. The Manufacturer does not accept any responsibility regarding damage of the pump caused by improper use.*

1.2.1- Equipment Misuse Hazard

- Fluid to be transferred by the diaphragm pump is notified to authorized dealer or main dealer. The dealer determines pump that is compatible with the fluid. Consult to VESTAPOMP or authorized dealer before pumping any other fluid than notified fluid transfer.

- Working pressure of the diaphragm pump is (max.) 7 bar. These pressure values shall not be exceeded. Otherwise, the pump can be damaged for which the warranty shall be null and void.

- Use noise preventive ear plugs, protection goggles and gloves during first installation, commissioning and continuous operation of the pump.

- While diaphragm pump is in operation and under

pressure, do not lift the pump.

- Comply with the related fire, electrical and safety regulations. (Local, National and Regional)

- Do not make any alteration on parts of the diaphragm pump. Always use (OEM) original spare parts.

- If a flexible hose is used for installation of the diaphragm pump, ensure that this hose is not bended during transfer.

- Hose in suction part should not be flexible during or after installing the diaphragm pump. Flexible hoses may be bended during suction and stop suction.

- Fluid to be transferred by the pump and pump body and elastomer (parts manufactured from rubber) materials shall be compatible. If you are not sure if they are compatible, consult VESTAPOMP or authorized dealer.

- Consider warnings of the manufacturer of the fluids to be transferred with the diaphragm pump.

- Check diaphragm pump body, its diaphragms and other equipment everyday. If any wear and tear is observed, immediately replace the part. When the diaphragm pump stops to operate and removed from line, if there is risk that fluid in it freezes, clean inside with a fluid compatible with this fluid. Otherwise, material freezing in the diaphragm pump may damage the body and diaphragms.

- Do not transfer trichloroethane, methylene chloride, other halogen hydrocarbon solvents or fluids containing such solvents in aluminium equipment that operate under pressure with these pumps. Use of these fluids may cause chemical reaction, which can possibly lead to explosions.

- Compliance of fluid to be transferred with pump body and elastomer parts shall be determined while selecting diaphragm pump. Selection of incompatible pumps or fluids, or use of these other than their intended use can cause damage to the pump, and even personal injury and death risk. the Manufacturer is not responsible for any and all damages that may occur, if fluid to be transferred and pump body are incompatible, if VESTAPOMP have not made this selection.

- Make diaphragm pump connections at original inlet and outlet size. Modification or reduction of inlet-outlet dimensions of the pump can cause damage to the pump, and early deformation of some parts. The Manufacturer shall not be responsible for faults and spare part losses of the pump, and the pump faults shall be excluded from the warranty in case of such modifications.



1.2.2 - Toxic Fluid Hazard

If toxic fluid or fume contacts with eyes or any part of the body during transfer, there may be permanent damages and may cause death risk. Therefore;

- The user shall have knowledge of the properties of the fluid to be transferred with the diaphragm pump. Take preventive actions against contact of the toxic or harmful fluid with environment, in line with such knowledge.
- Do not move, lift or disassemble the diaphragm pump when it is under pressure during transfer of hazardous and toxic fluids.
- Keep dangerous fluid in an approved container that fluid will not damage.
- Approach fluid transferred next to diaphragm pump during toxic and dangerous fluid transfers with compatible protective apron, clothes, gloves, goggles and mask.
- Notify absolutely that pumps sent to VESTAPOMP and authorized dealer for repair are used for toxic or dangerous fluid transfer.
- Relieve exhaust air (pressure outlet) of the pumps used for toxic fluid transfer to areas that will not damage anything. When the diaphragms burst, the toxic fluid or gas in the pump will be discharged from pressure outlet.
- Make pipe connections of the pump to which dangerous fluid shall be transferred in a controlled manner.
- Clean these fluids with the fluids that can clean them before transferring toxic, acidic and explosive fluids beforehand and empty fluid in the pump.
- These marks were attached on them while dispatching the pump.



1.2.3-Fire and Explosion Danger

Installation in non-ventilated environments and proper grounding of the pumps that are used in transfer of fluids having fire and explosion danger may cause dangerous situations. In this case, there may be serious injuries or even deaths.



- The pumps transferring combustible, and flammable fluids shall be grounded against static electricity. (See Figure 4)

- Do not transfer non-conductor inflammable fluids with non-conductor pump body materials (Polypropylene, PVDF).
- Stop the pump in case of any electric shock or sparks while using the pump. Do not operate the pump without being sure that problem was resolved.
- If the pump transferring a combustible fluid is used indoors, ventilate the ambient.
- Carry air outlet to a safe environment using a pipe. Thus, possible accidents caused by discharge of combustible materials in case of diaphragm bursts can be prevented. (See Figure 3)
- Do not smoke in an area where pump is installed and do not use lighter, do not weld.
- The pipe installed in the suction line of the diaphragm pump used for combustible and explosive fluid transfer shall not be flexible. Otherwise, vacuum created by the diaphragm pump during suction may cause shrinking of the elastic pipe, and it may also stop fluid suction. Besides, adhesion of surfaces due to the vacuum can cause tearing of the pipe. These tears may cause combustible and explosive fluid leaks.
- Use protective clothes, protective goggles and face mask during installation or repair of the pump used for transfer of combustible and explosive fluids.
- Take necessary safety precautions if the diaphragm pump is to be used for transfer of combustible and explosive fluids, or fluids at 80°C and higher temperatures.



CAUTION *The pump is delivered to the user without any equipment. Protective equipment and transfer equipment shall be provided by the user.*



CAUTION *The pumps to be sent to the manufacturer or the authorized service shall be drained in a way to prevent damage to the package or the environment. The Manufacturer or authorized dealer shall be informed of the explosive, combustible and harmful fluids transferred with the pumps to be sent to the Manufacturer or authorized dealer for service. The Company using the pump shall be responsible for any injuries and even deaths that may occur.*

2-Installation

2.1- General Information

Installation of the diaphragm pump is simple. However, if installation characteristics recommended by the Manufacturer Company are considered, working life of the pump shall be long and have high efficiency. (See Figure 1).

Ensure that there are no leaks and flow from thread connections when installing the connections (pipes, hoses, fittings, etc.) on the air and fluid lines during installation of the diaphragm pump. All connections shall be tightened securely. Use liquid seal when necessary.

- All bolt and nut connections shall be checked before installation of the diaphragm pump, and re-tightened when necessary. The vibrations occurred during transportation of the pump may cause loosening of these fasteners.

- If the difference between the air pressure supplied to the diaphragm pump and the fluid pressure discharged is more than 25%, then the pump operates inefficiently. Transferred fluid is very dense. This can be prevented by increasing weights of balls used as check valve, or by using stainless steel balls.

- Rubber wedges shall be placed under the pump brackets during installation of the diaphragm pump. This is recommended by the Manufacturer. Rubber wedge decreases the stress to the pump, prevents dismantling of bolts due to vibration, and also prevents material fatigue.

- The diaphragm pump shall be installed as close as possible to the fluid to be transferred.

- Length of the suction line and number of fittings should be kept minimum during installation.

- Diameter of the suction line of the installed pump shall not be reduced.

- If the pipe line at the place of installation of the diaphragm pump is not flexible, a flexible hose shall be placed between the pipe line and the pump.

- Our Exproof (explosion-proof) Pumps having ATEX certificate, can be used in explosive environments.

- The following (Figure 1) installation diagram is for providing information and guidance to the user on installation of the pump. It guides the user of the pump to install its own system in line with its needs. Consult to VESTAPOMP or authorized dealer for more information and document.

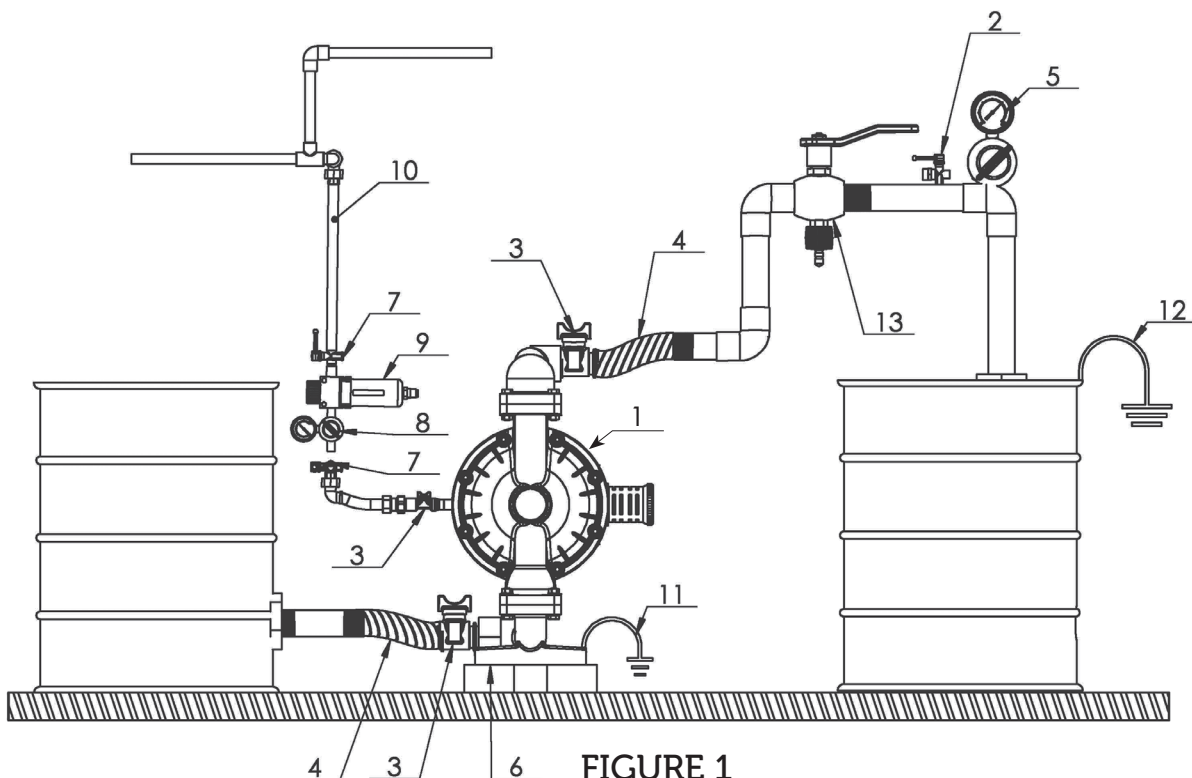

1- Aodd Pump

2- Fluid Relieve Valve

3- Fluid Shutoff Valve

4- Grounded, Flexible Fluid Outlet Line

5- Manometer

6- Rubber Wedge

7- Ball Valve (to control air flow)

8- Manometer (air pressure measurement)

9- Air Filter / Regulator Assembly

10- Air Supply Line

11- Fluid Section Grounding Via Grounding Strip or Grounding Screw (Required for Metal and Acetal Pumps)

12- Grounding Wire

13- Fluid Drain Valve (Required)

2.1.1- Safe Working Temperature for Body

	max.
Polypropylene	65°C
Aluminium	85°C
Stainless Steel	85°C
PVDF	85°C
Cast Iron	85°C
Glass Fiber Polypropylene	85°C
Stainless Sheet	85°C

2.1.2- Safe Working Temperature for Elastomer Parts

	max.	min.
<p>Neoprene Its resistance to vegetable oils are very good. Its resistance to abrasion is high. It is preferred to be used in neutral chemicals, grease oils and some solvents. Since Acids, Esters and Ketones damage to material structure, they are unpreferable transfer fluids.</p>	80°C	-23 °C
<p>Buna-n It is generally used in oils. Its use resistance in water and hydraulic oil transfer is high. It can be used easily in fuel and derivatives.</p>	80°C	-23 °C
<p>EPDM Its resistance to chemicals is good. It cannot resist very much towards oil and solvents. Its resistance in alcohols and ketons is at medium level.</p>	85°C	-23 °C
<p>PTFE It is generally used in heavy chemicals and acids. It has great resistance. It is very compatible for fluid transfers in high temperatures.</p>	85°C	-37 °C
<p>Viton Many of solvents and oils have great chemical resistance. It is preferred in hot water and hot solutions in some acids in animal and vegetable oils.</p>	85°C	0 °C
<p>Santoprene It has good resistance to acids and oils. Its mechanical flexibility and flexibility life is long. Abrasion resistance is high.</p>	85°C	-23 °C



CAUTION *The working temperature values of the materials specified above are given by considering the operating conditions of the diaphragm pump.*

2- 2 Air Line

Pressure from the air line connected to the pump shall not exceed 7 bar. Install the air line pipe with a diameter which is not less than the connection diameter to ensure required efficiency of the pump. Air line connection size is 3/4 in VP 15 type pump. Install air line of the pump as shown in **Figure 1**. Ensure that the air line between the main air line and the pump is flexible. Place a cut-off valve (ball valve) before the air line coming to the pump. Close air inlet from this valve when necessary or if pump air is cut off.

- Make air line connection as shown in **Figure 1**. Connect accessories to the wall or to a fixed place. Make sure that air line conducts electricity.

- Place conditioner (air regulator) in the upstream of the air line of the diaphragm pump. Water in pressurized air line may cause problems such as frost or freezing of the exhaust air. These problems can cause improper operation or complete failure of the pump. The moisture and water content of the pressurized air supplied by the compressor can be

reduced by means of a steam trap provided by the user, along with the air drying unit. This will prevent entrance of polluted air to the pump. Besides, it will decrease or prevent freezing in outlet line by keeping an amount of water within line.

- Open the air valve between 1/2" to 3/4" to start the pump. Air flow to the air valve can be adjusted to the desired level after starting the pump. If opening the valve increases the frequency but not the flow rate, then there is a cavitation in the fluid suction line. In this case, decrease the air supplied to the valve gradually, and activate the pump slowly. Thus, cavitation is prevented.

- Fluid flow in the diaphragm pump is controlled in two ways: either by controlling pressurized air line entering in the pump with a pressure regulator, ball valve or solenoid valve or by controlling fluid outlet line of the pump with a pressure regulator, ball valve or solenoid valve.

CAUTION *The air trapped between the air line connected to the diaphragm pump (number 3 in figure 1) and the pump itself must be discharged. Otherwise, the trapped air causes unintended start of the pump. This may cause accidents and poisoning due to moving parts.*

2.3- Suction Line

Connection of the pump to main suction line after suction nozzle shall be made with flexible hoses. This prevent breakage and deformation of some parts and loosening of the bolts of the pump during strokes.

- Place a cut-off valve in the upstream of the suction line during installation of the pump. The valve shall convenient removal of the pump during repair and maintenance.
- The manometer of the line allows checking if the fluid in the suction line flows properly.
- Ensure that the flexible and main line pipes to be connected to the suction line are conductive. Ground the pipes if the pipes are not conductive.
- Fluid inlet pressure higher than 1 bar reduces service life of the diaphragm. The most common example of this is the reduced life of the diaphragms in the diaphragm pumps connected to large-volume tanks due to the pressure of the tank.
- The suction is from the bottom due to construction in ball check valve diaphragm pumps.

2.4- Compression Line

The discharge line shall also be connected to the main line with a flexible hose in order to avoid loosening of

bolts and damage to the parts of the pump due to strokes of the pump.

- Place ball cut-off valve before the compression line in a way to be close to the pump. (See Figure 1)
- Place a manometer in the upstream of the discharge line read the pressure. (See Figure 1)
- Ensure that the flexible and main line pipes to be connected to the discharge line are conductive. Ground the pipes if the pipes are not conductive. (See Figure 1)
- Place a fluid relief valve or purger to relieve the pressure on the discharge line. This valve prevents splashing of harmful fluids to eyes and skin during discharge of the fluid. It prevents serious injuries. These injuries may cause death.

CAUTION *Do not tighten connection parts with excessive torque during installation. This can cause damage to the pump.*

2.5- Relief Valve for Fluid Pressure

Expansion of the fluid in discharge line with increasing temperatures causes increase of pressure within the line. This can be observed in long discharge lines exposed to the sunlight and other environmental factors. This may also occur when the valves in the high pressure pumps supported with diaphragm pump do not function properly. In these cases, it is recommended to set up pressure relief mechanism as it is seen in Figure 2 (by-pass line).

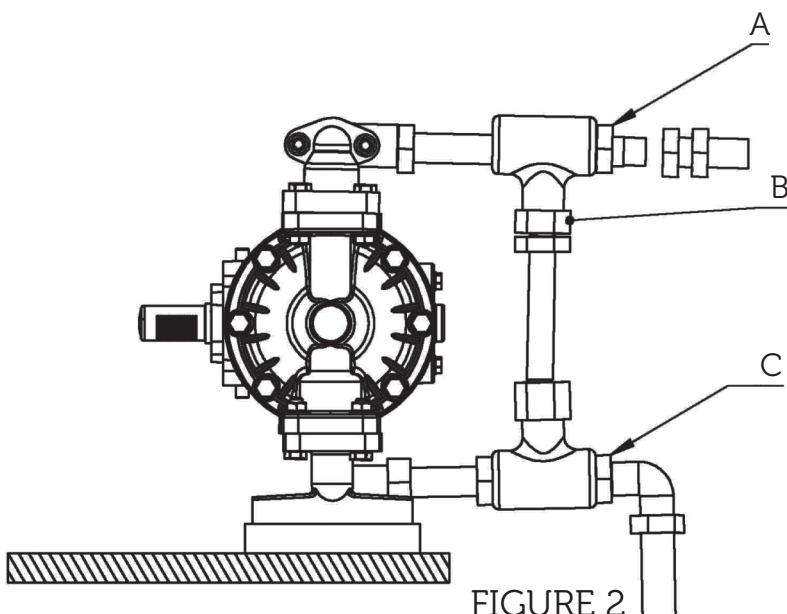

FIGURE 2

A- Connect fluid outlet line here

B- Install valve between fluid inlet and outlet holes

C- Connect fluid inlet line

CAUTION A pressure relief valve should be used in systems working under high pressure. This by-pass system prevents excessive increase of the pressure, thus penetration of the pump or the hose. (See Figure 2)

2.6- Outlet Air Discharge

The ambient shall be ventilated properly according to the system configuration. If the fluid transferred by the pump is toxic, combustible or explosive, the air outlet shall be placed away from persons, other living beings, food premises and all other combustible environments.

- Excessive restriction of the air outlet causes inefficient and unbalanced operation of the pump.
- The air outlet shall be installed so that the exhaust air is collected in a vessel by considering the risk of diaphragm bursts if the pump is used for harmful fluid transfer You can see this in **Figure 3**.

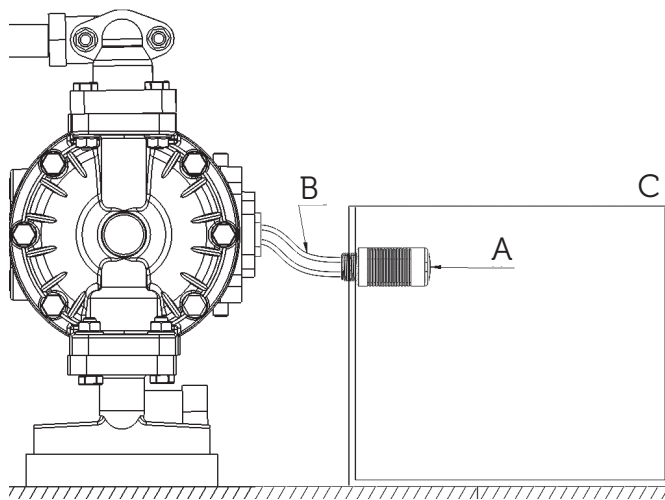

FIGURE 3

- A - Muffler
- B - Electrically Conductive Air Exhaust Hose
- C - Container For Remote Air Exhaust

2.7- Grounding

CAUTION The diaphragm Pump shall be grounded against the static electricity.

Ground the diaphragm pump as shown below (**Figure 4**). Surfaces that contact with fluid in the diaphragm pump shall be grounded with a stainless metal wire or a power cable as shown in the figure. Suction and discharge lines shall be made of conductive materials for transfer of combustible and explosive fluids. Both lines **MUST** also be grounded in the same way as described for the pump. Never use nonconductive polypropylene and PVDF bodies for transfer of combustible and and explosive fluids.

All equipment shall be grounded to prevent sparks and fires that may occur due to static electricity, and to mitigate risks (pump, air and fluid hoses, air compressor, inflammable matter buckets, fluid supply container and etc.).

- Clamps shall also be grounded in the clamp type pumps.
- Electrical resistance of fluids in diaphragm pumps shall be less than 2×10^{12} ohm centimetres.

CAUTION Cross section of the grounding cables of the exproof pumps shall be minimum 6.5 mm. Besides, HFFR (Halogen free flame retardant) cable shall be used, rather than any standard cable. The points for connection of the cables are specifically marked on the pump. This cable shall be provided by the customer.

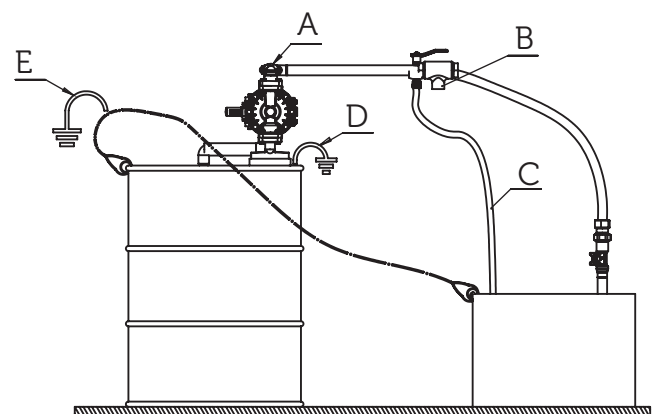

FIGURE 4

- A - AODD Pump
- B - Fluid Relief Valve
- C - Fluid Drain Line
- D - Grounding Strip (Grounding Screw)
- E - Container Grounding Cable

2.8 - Washing and Cleaning the Pump

The diaphragm pump to be installed is subjected to hydrostatic pressure and leakage test by the manufacturer. Wash the pump with a compatible solvent or compatible fluid if the pump is to be used for transfer of foodstuffs or a fluid which reacts with water.

2.9- Commissioning of the Pump

Connection of the diaphragm pump is very simple. The fluid is sucked into the pump through the bottom inlet pipe which is the suction inlet of the pump, and the transfer fluid discharged through the upper outlet pipe which is the discharge outlet of the pump. Diaphragm pumps have a knocking flow. One of the ways to prevent knocking flow is to install a flexible hose in the upstream of the inlet and outlet line of the pump in installation place. Another way of regulating flow is to place a damping medium (balance tank, tranquillizer) in the upstream of the discharge line. Manometer and valves are placed to inlet and outlet line to determine pressure values that may occur in inlet and outlet of the pump, and to adjust flow rates. When one valve or both valves are closed, the pump does not operate. When both valves are opened, the diaphragm pump continues to operate. The diaphragm pump is not damaged in the meantime. Pressurized air is needed so that diaphragm pump operates. The air inlet hose shall have the same diameter with the air inlet line to allow operation of the pump with full capacity. Installation of a conditioner in the upstream of the air inlet line is recommended by the Manufacturer. The conditioner controls pressure adjustments and lubricates air diverter valve. Fluid flow rate is adjusted by controlling air flow with valve to be placed in the upstream of the air inlet line.

Subjects to be considered while installing the diaphragm pump;

- The diaphragm pump shall be installed as close as possible to the fluid to be transferred.
- The length of the suction line and the number of bends in the suction line shall be kept minimum. Inlet-outlet dimension of the diaphragm pump should not be different from connection size in a place where installation was made. Pipe connections should be made flexible in a place where the diaphragm pump was installed.

- If the pump does not suck fluid when it is started, then there is a cavitation in the suction line.

Cavitation causes reduction of the service life of diaphragms. Check the suction height. Do not operate the pump at high speed, control suction line diameter. These may cause cavitation.

Control all threaded connections and air connections against leakage and leaks during first commissioning of the pump. If there is any leak, its entering in inflammable, explosive or acidic fluid environment may constitute risk.

Damping tanks should be used to prevent knocking in the pipe line in long push distances.

2.10- Pressure Equipment Relief

The pump and equipment are under pressure until pressure in the pump is relieved. While the pump is in this position, accidental splashes, splits and sprays from the pump and the equipment can cause injury to the user. Apply pressure relief procedure to avoid injuries and risks.

Apply the pressure relief procedure when;

- The pressure should be relieved
- You stop the pump
- Check, clean or perform maintenance of any system equipment.

How to relieve pressure?

- Close the air line entering in the pump from the valve. Open air pressure relief valve for relieving pressure air remaining between the air line valve and the pump.
- Close the valve in the push line. Place a suitable container under the fluid pressure relief valve before opening it. Drain the remaining fluid into the container. Remove outlet hose from the pump.

How to drain the fluid remaining in the pump?

- Wear clothes compatible with the fluid transferred by the pump
- Close any valves on the suction of the pump, use a compatible container to collect the fluid that will flow or drop from the suction hose
- Remove the suction hose from suction nozzle. Remove it if it is connected to ground (figure 5)

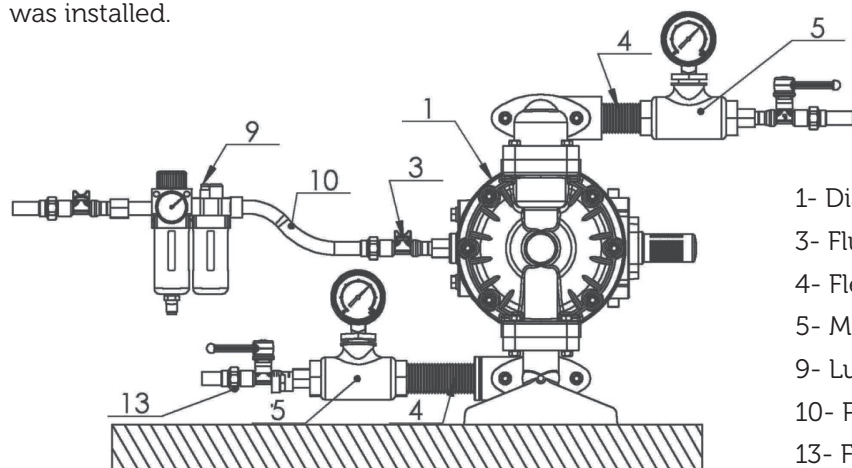

FIGURE 5

- 1- Diaphragm Pump
- 3- Fluid Cut-off Valve (ball valve)
- 4- Flexible Hose
- 5- Manometer (fluidization measurement)
- 9- Lubricator
- 10- Pressure Line
- 13- Fluid Cut-off Valve (ball valve)

3-OPERATION

3.1 Technical Information

3.1.1- Performance Curve and Pump Figure

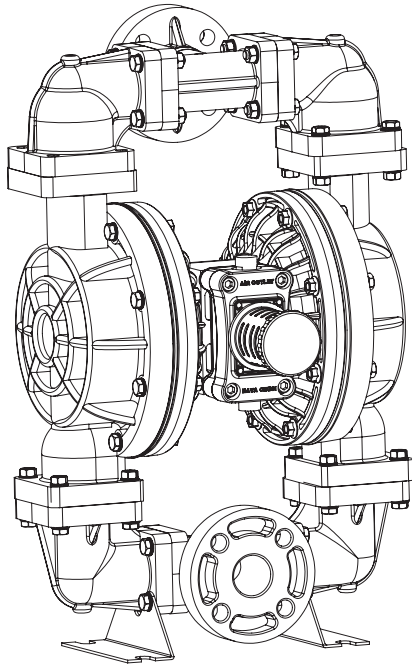

Plastic Body

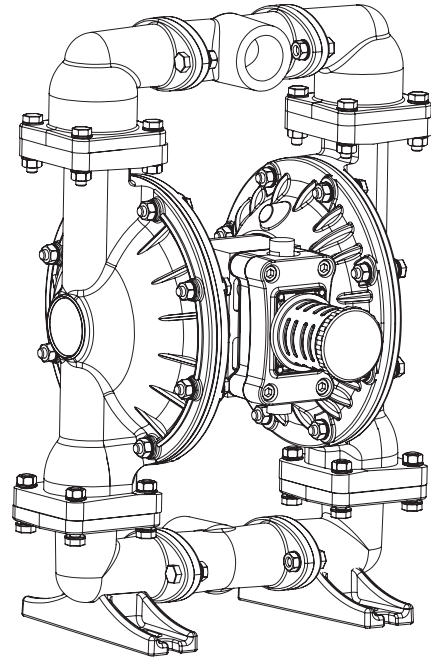

Aluminium Body

Performance Curve of VP 15 (1.5") Diaphragm Pump

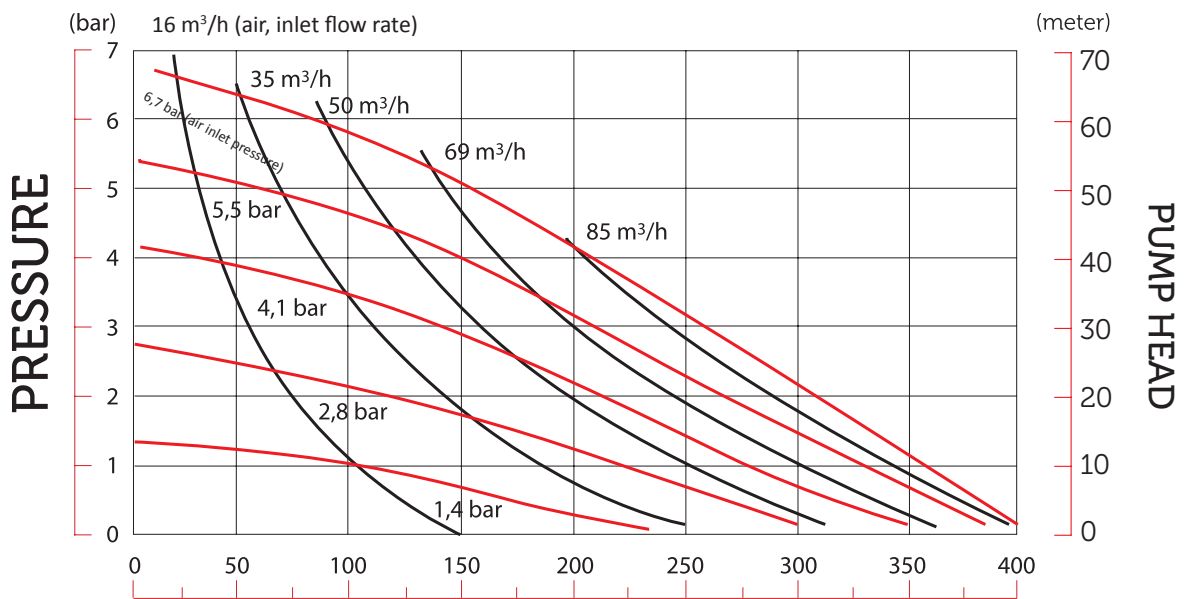

Capacity in Liter per minute (lt/min.)

- The teflon diaphragms in the pump can cause a flow rate loss up to 25%. The reason is that no supportive diaphragm is used behind teflon diaphragm in the pump. Increase of total hardness in used diaphragm and decrease of pump efficiency.

3.1.2- Pump Type Coding

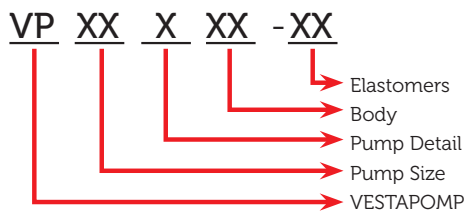
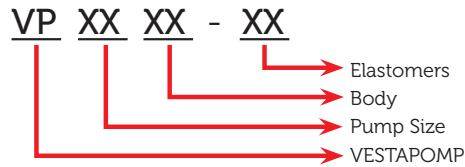

Body	
AL	Aluminium
DD	Cast Iron
SS	Precision Casting
SC	Sheet Stainless Steel
SK	Sand Casting Stainless Steel
PP	Polypropylene
PB	Glass Fiber Polypropylene
PVDF	PVDF

Pump Detail	
E	Electrical
T	Dust
C	Dual Outlet
W	All Parts Aluminium

Elastomers		
	Diaphragm	Ball
N	Neoprene	Neoprene
B	Buna - N	Buna - N
S	Santoprene	Santoprene
E	EPDM	EPDM
T	PTFE	PTFE
V	FKM	FKM
C	-	Steel
TV	PTFE	FKM
TC	PTFE	Steel
TE	PTFE	EPDM
SV	Santoprene	FKM
ST	Santoprene	PTFE
SB	Santoprene	Buna - N
SC	Santoprene	Steel
SN	Santoprene	Neoprene
NC	Neoprene	Steel
BC	Buna - N	Steel

Pump Size	
02	1/4"
05	3/4"
10	1"
15	1 1/2"
20	2"
30	3"

* Our exproof pumps with ATEX Certification are suitable for use in explosive atmospheres.

3.1.3- Spare Part Type Coding

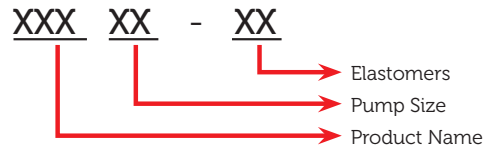

Elastomers		Pump Size	
45	Neoprene	02	1/4"
46	Santoprene	05	3/4"
47	Buna - N	10	1"
48	EPDM	15	1 1/2"
50	PTFE	20	2"
51	FKM	30	3"
30	Aluminium		
31	Casting		
32	Stainless		
33	Polypropylene		
35	PVDF		

3.1.4- Technical Specifications of the Pump

Max. Capacity	: 400 lt/min
Fluid Inlet-Outlet	: 1 1/2"
Max. Fluid Discharge Pressure	: 7 bar
Discharge Height (max)	: 70 m
Body Material	: Aluminium, PVDF Sand-Cast Stainless, Stainless Sheet Polypropylene, Glass-Fiber Polypropylene
Diaphragm	: Santoprene, Neoprene, Buna-N, EPDM, PTFE, FKM
Ball	: Santoprene, Neoprene, Buna-N, EPDM, PTFE, FKM, Stainless Steel, Steel
Ball Seat	: Santoprene, Neoprene, Buna-N, EPDM, PTFE, FKM, Aluminium, Stainless Steel, Steel Polypropylene
Air inlet Diameter	: 3/4"
Solid particle Permeability Size:	6 mm
Dry Suction Depth	: 6 m
Air Pressure (Min, Max.)	: 1-7 bar
Working Temperature	: -18 °C ile 100 °C
Noise Level	: 79 dB
Flow in one Stroke	: 1,76 lt/min.

3.1.5- Pump Scaling

Metal Body

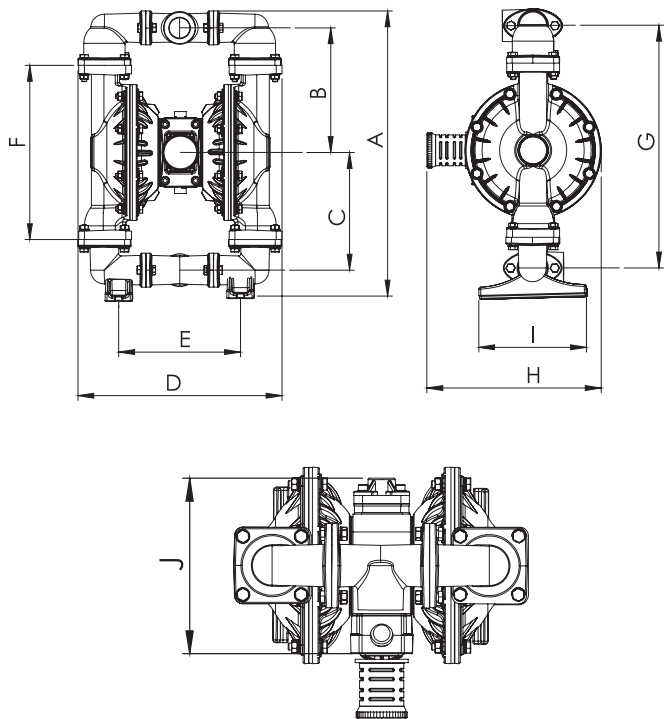

A	B	C	D	E	F	G	H	I	J
605	260	245	425	253	363	505	363	224	253

Plastic Body

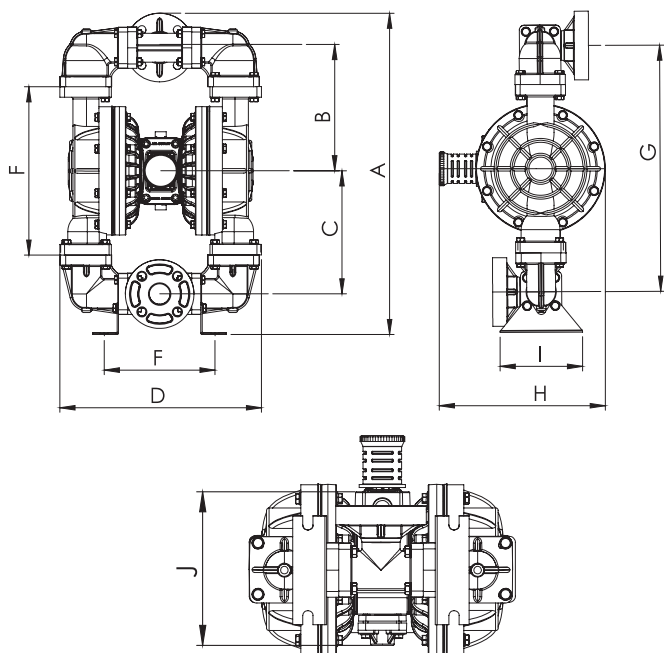

A	B	C	D	E	F	G	H	I	J
703	276	269	440	242	368	538	363	180	254

3.1.6- Packaging Sizes and Weights

As it is seen in the following figure, the diaphragm pump is connected to pump fixing board from its stands via bolt and nut. Lean of the pump is prevented during transport.

Scaling with Metal Body

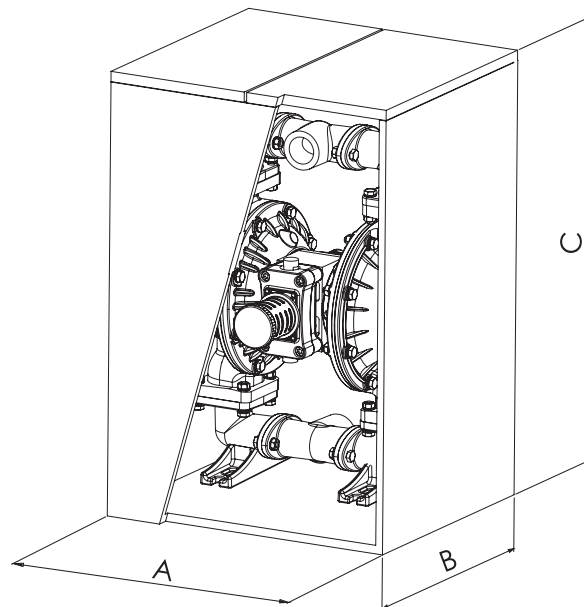

Pump Weight : 24,3 kg
 Package Weight : 2 kg
 Gross Weight : 26,3 kg

A	B	C
440	340	740

Scaling with Plastic Body

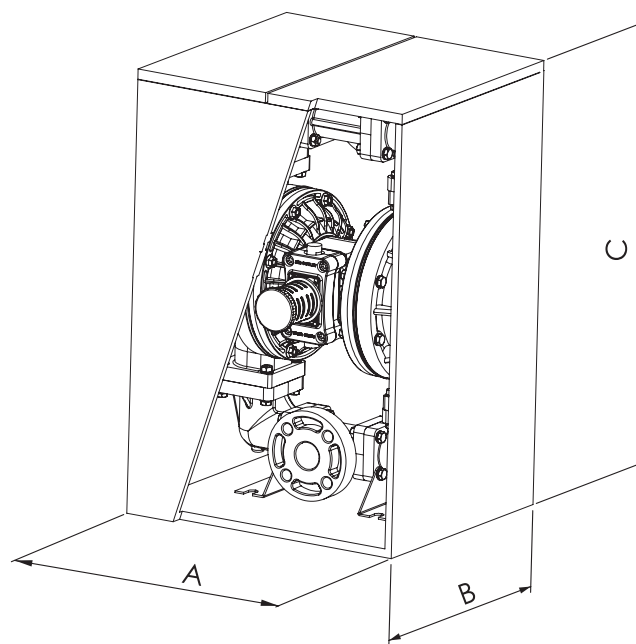

Pump Weight : 19,68 kg
 Package Weight : 2 kg
 Gross Weight : 21,68 kg

A	B	C
440	340	740

3.1.7- Spare Parts Drawing (Metalling Body)

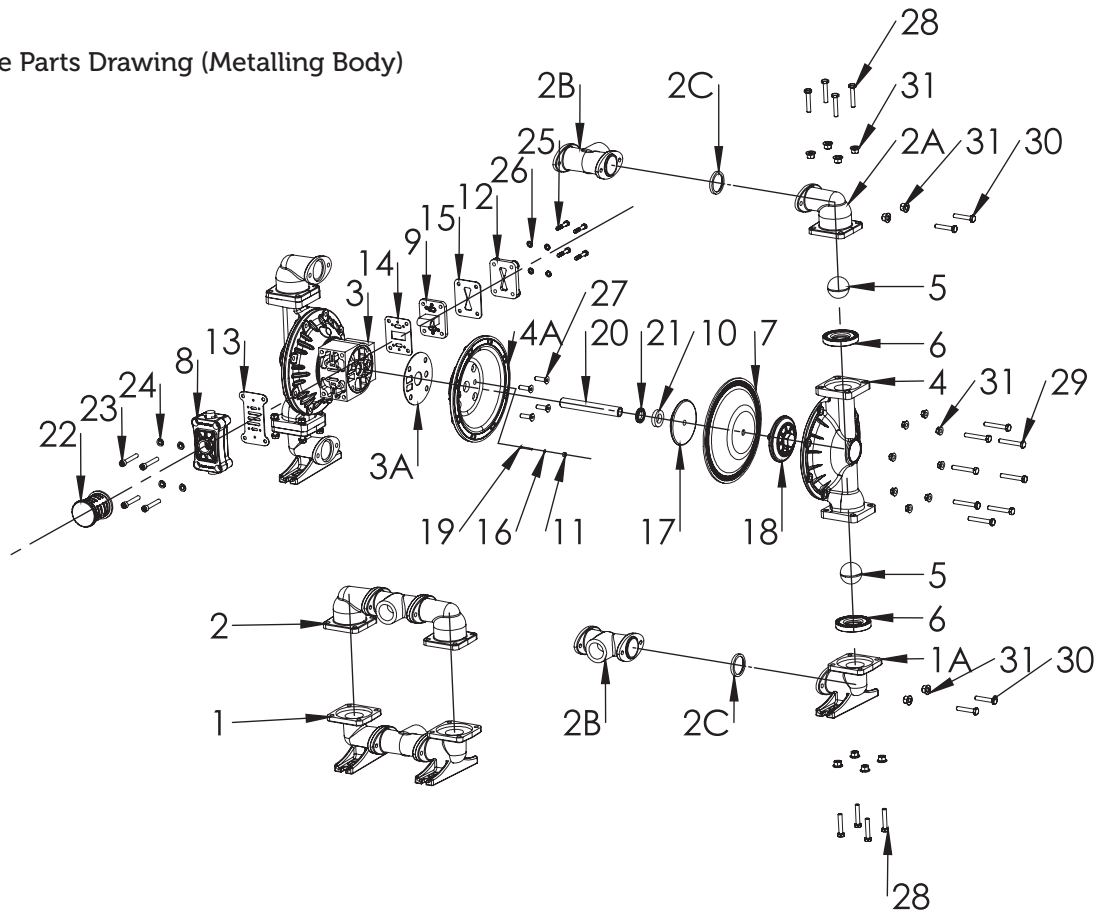

VP15 METAL BODY PUMP PARTS LIST

ITEM NO	PART NUMBER	DESCRIPTION	PIECE	ITEM NO	PART NUMBER	DESCRIPTION	PIECE
1	S011530	SUCTION LINE	1		S061547	DIAPHRAGM	2
	S011531	SUCTION LINE	1		S061548	DIAPHRAGM	2
	S011532	SUCTION LINE	1		S061550	DIAPHRAGM	2
1A	S261530	ELBOW, SUCTION	2		S061551	DIAPHRAGM	2
	S261531	ELBOW, SUCTION	2	8	H034033B	AIR VALVE KIT	1
	S261532	ELBOW, SUCTION	2		H034030	AIR VALVE KIT	1
2	S021530	DISCHARGE LINE	1	9	H044033B	PILOT VALVE KIT	1
	S021531	DISCHARGE LINE	1	10	H055047	BUMPER	2
	S021532	DISCHARGE LINE	1	11	H064033B	BUSHING, PLUNGER	2
2A	S601530	ELBOW, DISCHARGE	2	12	H075033B	CAP, AIR INLET	1
	S601531	ELBOW, DISCHARGE	2	13	H084047	GASKET, AIR DISCHARGE	1
	S601532	ELBOW, DISCHARGE	2	14	H094047	GASKET, INTERMEDIATE BRACKET	1
2B	S241530	MANIFOLD	2	15	H104047	GASKET, VALVE BODY	1
	S241531	MANIFOLD	2	16	H124047	ORING, FOR PIN	1
	S241532	MANIFOLD	2	17	H131530	PLATE, INNER DIAPHRAGM	2
2C	S161546	SEAL, MANIFOLD	4	18	S071530	PLATE, OUTER DIAPHRAGM	2
3	H015033B	MAIN BODY	1	19	H145032	PLUNGER, ACTUATOR	2
3A	H115047	GASKET, INNER CHAMBER	2	20	H151532	SROD, DIAPHRAGM	1
4	S031530	CHAMBER OUTHOR	2	21	H165047	OIL SEAL	2
	S031531	CHAMBER OUTHOR	2	22	H174033B	MUFFLER	1
	S031532	CHAMBER OUTHOR	2	23	CM10x60-PI	CAPSCREW SOC HEAD M10x60 STAINLESS	4
4A	H025030	CHAMBER, INNER	2	24	PM10-PO	WASHER M10 STAINLESS	4
5	S041545	BALL, CHECK	4	25	CM8x45	CAPSCREW 8x45	4
	S041546	BALL, CHECK	4	26	PM8	WASHER M8 STAINLESS	4
	S041547	BALL, CHECK	4	27	CM10x25-PHBI	CAPSCREW, SOC HD 10x25 STAINLESS	8
	S041548	BALL, CHECK	4	28	CM10x50	CAPSCREW 10x50	16
	S041550	BALL, CHECK	4	29	CM10x45	CAPSCREW 10x45	16
	S041551	BALL, CHECK	4	30	CM10x30	CAPSCREW 10x30	8
6	S051545	BALL SEAT	4	31	SM10-F	NUT HEX FLANGE M8	40
	S051546	BALL SEAT	4				
	S051547	BALL SEAT	4				
	S051548	BALL SEAT	4				
	S051550	BALL SEAT	4				
	S051551	BALL SEAT	4				
7	S061545	DIAPHRAGM	2				
	S061546	DIAPHRAGM	2				

3.1.7- Spare Parts Drawing (Plastic Body)

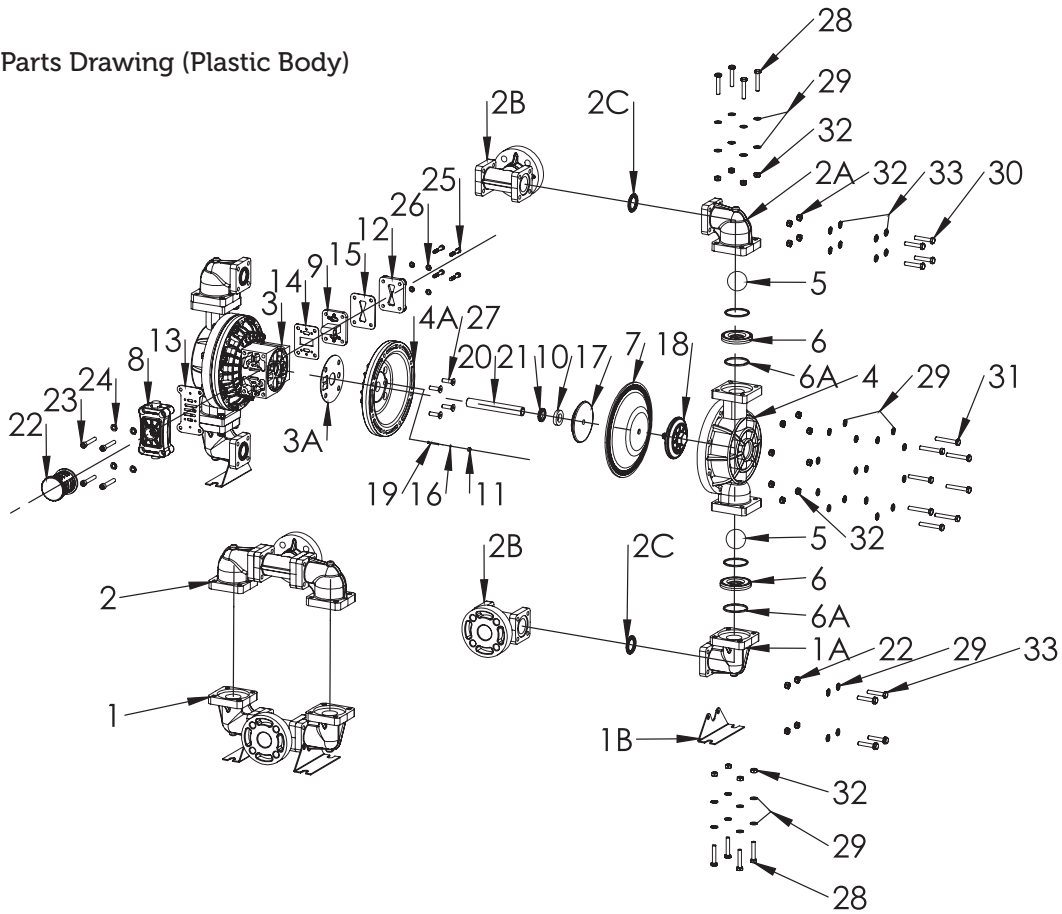

VP15 PLASTIC BODY PUMP PARTS LIST

ITEM NO	PART NUMBER	DESCRIPTION	PIECE	ITEM NO	PART NUMBER	DESCRIPTION	PIECE
1	S011533	SUCTION LINE	1	7	S061545	DIAPHRAGM	2
	S011533B	SUCTION LINE	1		S061546	DIAPHRAGM	2
	S011535	SUCTION LINE	1		S061547	DIAPHRAGM	2
1A	S261533	ELBOW, SUCTION	2		S061548	DIAPHRAGM	2
	S261533B	ELBOW, SUCTION	2		S061550	DIAPHRAGM	2
	S261535	ELBOW, SUCTION	2		S061551	DIAPHRAGM	2
1B	H301532	BRACKET, MOUNTING	2	8	H034033B	AIR VALVE KIT	1
2	S021533	DISCHARGE LINE	1		H034030	AIR VALVE KIT	1
	S021533B	DISCHARGE LINE	1	9	H044033B	PILOT VALVE KIT	1
	S021535	DISCHARGE LINE	1		H055047	BUMPER	2
2A	S601533	ELBOW, DISCHARGE	2	11	H064033B	BUSHING, PLUNGER	2
	S601533B	ELBOW, DISCHARGE	2	12	H075033B	CAP, AIR INLET	1
	S601535	ELBOW, DISCHARGE	2	13	H084047	GASKET, AIR DISCHARGE	1
2B	S241533	MANIFOLD	2	14	H094047	GASKET, INTERMEDIATE BRACKET	1
	S241533B	MANIFOLD	2	15	H104047	GASKET, VALVE BODY	1
	S241535	MANIFOLD	2	16	H124047	ORING, FOR PIN	1
2C	S161546	SEAL, MANIFOLD	4	17	H131530	PLATE, INNER DIAPHRAGM	2
3	H015033B	MAIN BODY	1	18	S071533	CAP, AIR INLET	2
3A	H115047	GASKET, INNER CHAMBER	2	19	H145032	PLUNGER, ACTUATOR	2
4	S031533	CHAMBER OUTHOR	2	20	H151532	SROD, DIAPHRAGM	1
	S031533B	CHAMBER OUTHOR	2	21	H165047	OIL SEAL	2
	S031535	CHAMBER OUTHOR	2	22	H174033B	MUFFLER	1
4A	H025033	CHAMBER, INNER	2	23	CM10x60-PI	CAPSCREW SOC HEAD M10x60 STAINLESS	4
5	S041545	BALL, CHECK	4	24	PM10-PO	WASHER M10 STAINLESS	4
	S041546	BALL, CHECK	4	25	CM8x45-P	CAPSCREW 8x45 STAINLESS	4
	S041547	BALL, CHECK	4	26	PM8-P	WASHER M8 STAINLESS	4
	S041548	BALL, CHECK	4	27	CM10x25-PHBI	CAPSCREW, SOC HD 10x25 STAINLESS	8
	S041550	BALL, CHECK	4	28	CM10x60-P	CAPSCREW 10x60 STAINLESS	16
	S041551	BALL, CHECK	4	29	PM10-P	WASHER M10 STAINLESS	94
6	S051545	BALL SEAT	4	30	CM10x55-P	CAPSCREW 10x55 STAINLESS	16
	S051546	BALL SEAT	4	31	CM10x70-P	CAPSCREW 10x70 STAINLESS	16
	S051547	BALL SEAT	4	32	SM10-P FIBERLI	NUT HEX M10 STAINLESS FIBER	32
	S051548	BALL SEAT	4	33	SM10-P	NUT HEX M10 STAINLESS	16
	S051550	BALL SEAT	4				
	S051551	BALL SEAT	4				
6A	S081546	GASKET, BALL SEAT	8				

4-MAINTENANCE

Clean the pump with a compatible cleaning fluid before starting maintenance, if the fluid transferred by the pump has drying and frosting characteristics. Otherwise, pump maintenance will be more expensive and difficult. Control bolt connections in each use. Tighten loose connections with a suitable wrench. Replace necessary connections.

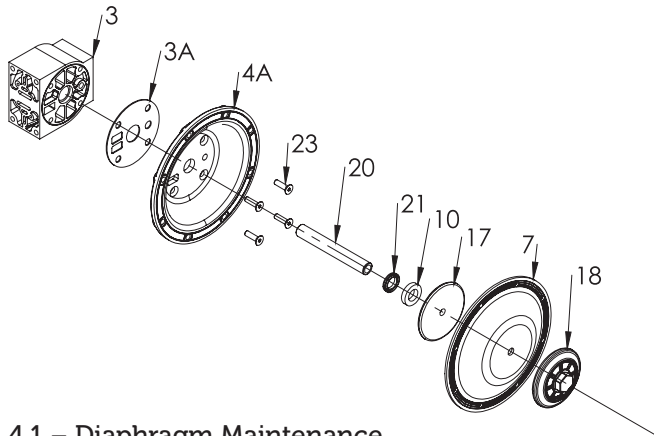

4.1 – Diaphragm Maintenance

Line	Part No	Part Name
3	H015033B	Main Body
3A	H115047	
4A	H025033B	
23	CM10x60-PI	Capscrew Soc Head M10x60 Stainless
20	H151532	Srod, Diaphragm
21	H165047	Oil Seal
10	H055047	Bumper
17	H131530	Plate, Inner Diaphragm
7	S0615XX	Diaphragm
18	S071533	Plate, Outher Diaphragm

CAUTION *Double diaphragm is used with options of teflon diaphragm pump. The rubber diaphragm used before the teflon increase the service life of the teflon diaphragm by improving its breakage and fatigue strength.*

Relieve pressure in the pump after closing pressure air and remove the pump from air inlet line. Drain the fluid in the pump. See pump installation figures and diaphragm maintenance schemes. Remove suction and discharge lines. Remove the ball and ball seats. Then, remove external covers of the pump.

4.1.1- Removal of the Diaphragms

Remove external diaphragm fastener by turning it counter-clockwise with a 34 socket wrench to remove diaphragm group from diaphragm shaft. One of the diaphragms shall be removed with internal and external diaphragm fastener and the other shall be removed as connected to the shaft. First, place the internal diaphragm fastener on a vice to remove the diaphragm between internal and external diaphragm fastener and tighten it, and remove it by turning it counter-clockwise with a 34 socket wrench.

Fasten the shaft connected to other diaphragm to the clamp loosely and remove it with the wrench. Repeat the same steps to remove the other diaphragm. Check the diaphragm for cut, puncture, wear and chemical exposure. Replace the diaphragms when necessary.

4.1.2- Installation of the Diaphragm

Fasten external diaphragm to fastener and push from central hole of the diaphragm to inside. Tighten the internal diaphragm to the shaft clockwise by installing bolt. Re-install loose group to the vice. Tighten diaphragm group with 34 socket wrench.

4.1.3- Installation of the Diaphragms to the Pump

Make sure that ram was installed on the diaphragm shaft. Tighten a diaphragm group shaft until it comes to same line with shaft end of internal diaphragm plate to threaded hole on diaphragm end clockwise. Install the shaft to the pump. Align bolt holes in the diaphragm with bolt holes of internal chamber. Connect external chamber to the pump by using bolts and nuts.

Pull the diaphragm shaft from the other end of the pump. Ensure that nose is installed on diaphragm shaft. Tighten open shaft of the diaphragm group to the diaphragm shaft clockwise as much as possible, and leave a gap to allow alignment of the bolt holes on the diaphragm with the bolt holes of the internal chamber.

Install the external chamber to the pump by using bolts, nuts and washers. Connect the suction and discharge lines to the pump by using bolts, nuts and washers. The pump is ready to be re-fastened and used.

4.2 – Air Valve Kit Types and Maintenance

Air valves are lubricated with special greases, and require no more greasing. Disconnect the air inlet to the pump once 1 or 2 weeks if additional lubrication is needed. Add 4-5 pumps of machine oil through the air inlet of the pump. (SAE 10)

H034033B Air Valve Repair Kit

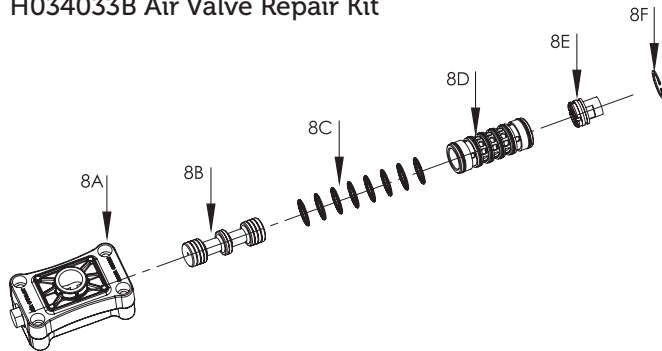

AIR VALVE (PLASTIC BODY) REPAIR KIT PARTS LIST

Line	Part No	Part Name
8A	H554033	Air Valve Body
8B	H724030	Spool, Air Valve
8B	H724070	Spool, Air Valve
8C	H574047	Orings, Air Valve
8D	H714030	Sleeve, Air Valve
8D	H714032	Sleeve, Air Valve
8E	H584033	Cap, End
8F	H504090	Ring, Retaining

H034030 Air Valve Repair Kit

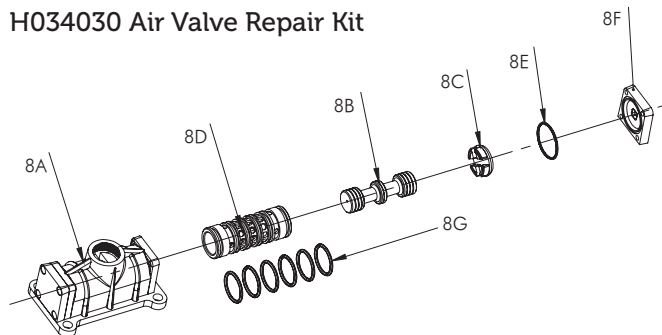

AIR VALVE (METAL BODY) REPAIR KIT PARTS LIST

Line	Part No	Part Name
8A	H554030	Air Valve Body
8D	H714030	Sleeve, Air Valve
8D	H714032	Sleeve, Air Valve
8B	H724030	Spool, Air Valve
8C	H604033B	Cap, End
8E	H694047	Orings, Air Valve
8F	H614030	Cap, Air Valve
8G	H574047	Orings, Air Valve

CAUTION Do not lubricate the pump excessively while making extra lubrication. This may cause mess and even malfunction.

H590532 Jacket-Piston Set

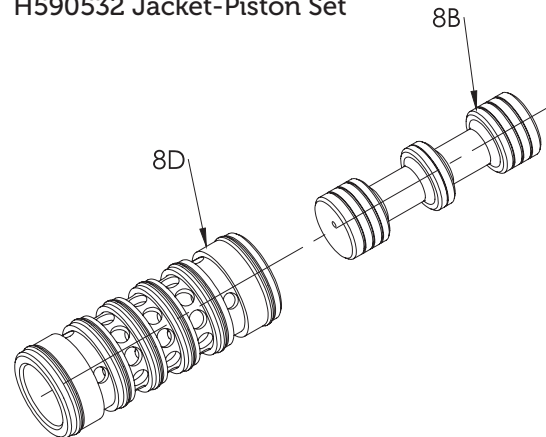

JACKET PISTON REPAIR KIT PART LIST

Line	Part No	Part Name
8D	H714030	Sleeve, Air Valve
8D	H714032	Sleeve, Air Valve
8B	H724030	Spool, Air Valve
8B	H724070	Spool, Air Valve

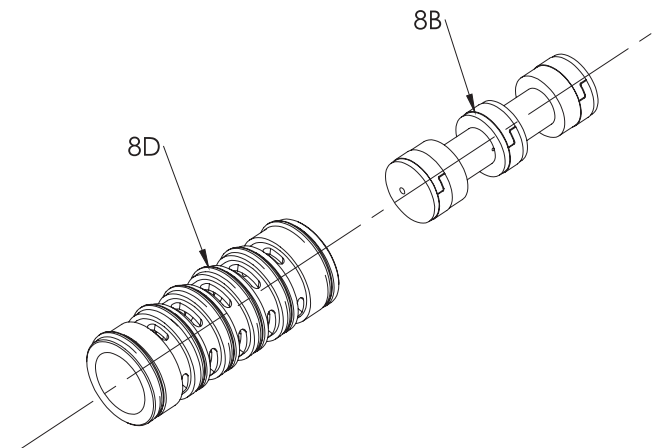

JACKET PISTON REPAIR KIT PART LIST

Line	Part No	Part Name
8D	H634032	Sleeve, Air Valve
8D	H634030	Sleeve, Air Valve
8B	H644030	Spool, Air Valve

4.3 – Pilot Valve Repair Kit Types and Maintenance
Close suction and push line of the pump before starting valve maintenance. Cut pressure air inlet and relieve pressure in the pump. Relieve fluid in the pump.

H044033B Pilot Valve Repair Kit

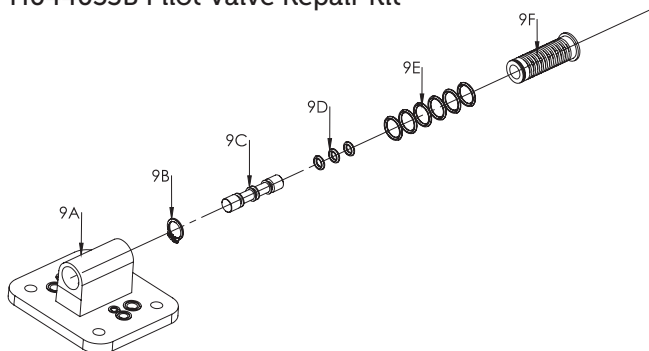

PILOT VALVE REPAIR KIT PART LIST		
Line	Part No	Part Name
9A	H454033	Pilot Valve Body
9B	S124090	Ring Retaining, for Pilot Valve
9C	H484032	Spool, Pilot Valve
9D	H498047	O-ring, for Pilot Valve Piston
9E	H478047	Orings, for Pilot Valve Case
9F	H464030	Sleeve, for Pilot Valve

See pump installation figures.
Remove four bolts by using wrench or socket. Remove air inlet cover and air inlet gasket. Pilot valve group can be removed for control and maintenance. You can remove pilot valve kit before removing the pump completely.

Remove pilot valve piston. Clean and control piston and o-rings for dirt, cut and wear. When necessary, replace o-rings and piston with new ones. Remove the segment from case end and case from the valve body and clean. Control case and o-rings for dirt, cut and wear. When necessary, replace o-rings and case with new ones.

Lubricate external surface and o-rings of the case abundantly. Then place the case in valve body carefully. PAY ATTENTION that o-rings are not cut while placing the case. Install the segments in case. Lubricate external surface and o-rings of the case abundantly. Then place the case in valve body carefully. PAY ATTENTION that o-rings are not cut while placing the case.

Pay attention that pilot valve ends are adjusted between piston pins while reinstalling pilot valve group to intermediate space gap. Reinstall gasket, air inlet cover and bolts. Connect air inlet to the pump. The pump is ready to be used.

4.4 – Actuator Plunger Maintenance

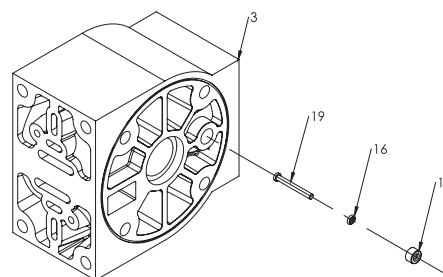

Line	Part No	Part Name
3	H015033	Main Body
19	H145032	Plunger, Actuator
16	H124047	O-ring, for Pin
11	H064033B	Bushing, Plunger

If the nose pin is damaged while operating under high pressure, and the problem insists when the pin is replaced, replace with a pin with larger cross section.

Close suction and discharge line of the pump before starting nose pin maintenance. Cut pressure air inlet, and relieve the pressure in the pump. Drain the fluid in the pump. See pump installation diagrams. Remove four bolts by using a wrench or socket. Remove air inlet cover and air inlet gasket. Pilot valve group can be removed for control and maintenance. Check the nose pins. Refer to the figure. Nose pins can be accessed through the opening among the pilot valve group. Remove the pins from the bushings on both sides of the pins. Check o-rings for dirt, cut and wear. Replace the o-rings when necessary. Apply a thin layer of grease on each o-ring, then place the pins on bushings. Push the pin forward. Pay attention that pilot valve ends are adjusted between piston pins while reinstalling pilot valve group to intermediate space gap. Install the gasket, air inlet cover and bolts. Connect the air inlet to the pump. The pump is ready for use.

4.5 – Plastic and Metallic Body Pump Check Valve Maintenance

Close suction and discharge line of the pumps before starting check valve maintenance. Cut pressure air inlet, and relieve the pressure in the pump. Drain the fluid in the pump.

Remove the bolts in fluid inlet and fluid Outlet lines in section shown in the figure to access the ball valve. Check spherical surfaces of the balls for wearing, abrasion or cuts. Ball slots should be controlled in terms of potential materials adherent on internal and external surfaces for cut and wear. Ball surfaces should be placed completely on surfaces of the ball seats. This affects the efficiency of the pump.

Replace worn and damaged parts when necessary.. Regroup check valve parts.

Plastic Body

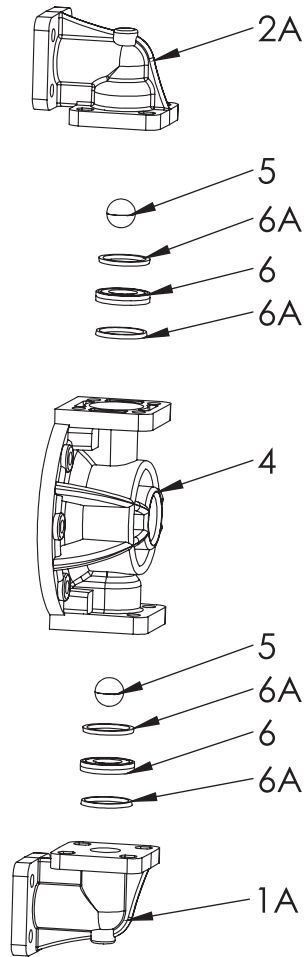

Line	Part No	Part Name
1A	S261533	Elbow, Suction
6A	S081546	Gasket, Ball, Seat
6	S0515xx	Ball Seat
5	S0415xx	Ball, Check
4	S031533	Chamber Outher
2A	S601533	Elbow, Discharge

Metal Body

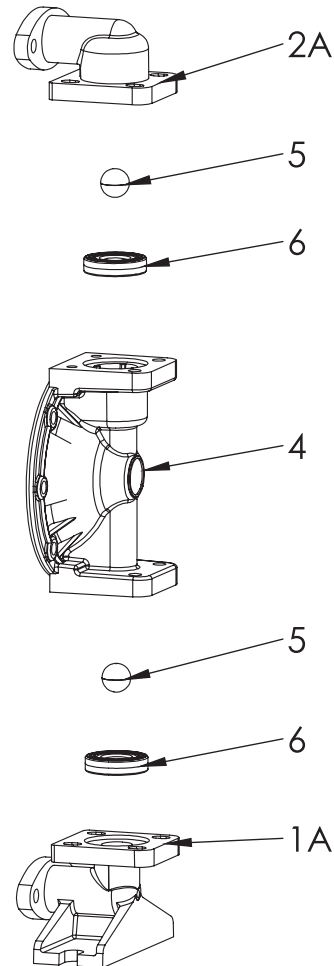

Line	Part No	Part Name
1A	S261530	Elbow, Suction
6	S0315xx	Ball Seat
5	S0415xx	Ball, Check
4	S031530	Chamber Outher
2A	S601530	Elbow, Discharge

CAUTION Feeders in external cover and Outlet manifolds should be controlled in abrasive fluid transfers during ball valve change. The fluid can cause rupture of balls by corroding feeders.

4.6- PROBLEMS THAT MAY OCCUR IN THE PUMP AND THEIR SOLUTIONS

If pressure air comes to the pump and pump does not operate, air directly gets out from the exhaust.	The case piston may be stuck. Air coming to the pump should be clean.	Remove and clean air valve
If the pump operates but does not suction	Parts may be pressurized between ball and ball slot.	Clean ball valves especially in suction section.
If the pump operates but fluid capacity is low	Air coming from the compressor may be less. Ball and ball slots may be abraded.	Control and if necessary replace with the new ones.
If pump transfer is unbalanced	Pilot valve may be malfunctioned	Replace with the new one
If there are bubbles in fluid coming from the pump	Suction line may be loose.	Compress
	Diaphragm may be perforated.	Replace
	Diaphragm retainers may be loose.	Compress
If liquid comes from the exhaust air	Diaphragm may be perforated.	Replace
	Diaphragm retainers may be loose.	Compress
	Compressor air is excessively moist.	Clean compressor tank.

4.7 – Torque Line in Plastic Body Pumps

AIR VALVE COVER

Tighten the bolts with 27N.m_30N.m torque

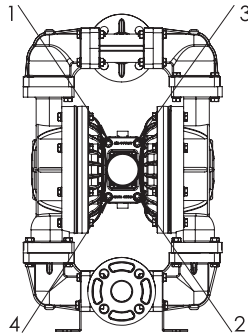

PILOT VALVE COVER

Tighten the bolts with 27N.m_30N.m torque

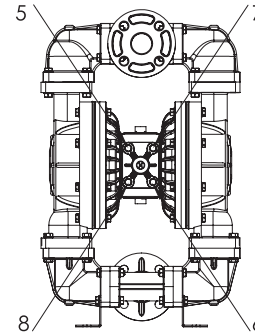

RIGHT-LEFT FLUID COVER

Tighten the bolts with 29N.m_32N.m torque

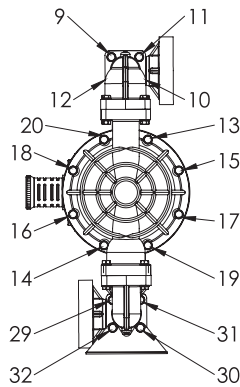

T ELBOW PART

Tighten the bolts with 27N.m_30N.m torque

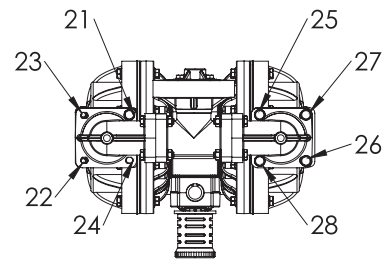

4.8 – Torque Line in Aluminium Body Pumps

AIR VALVE COVER

Tighten the bolts with 28N.m_31N.m torque

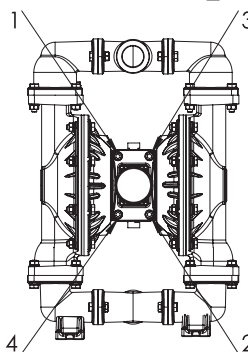

PILOT VALVE COVER

Tighten the bolts with 28N.m_31N.m torque

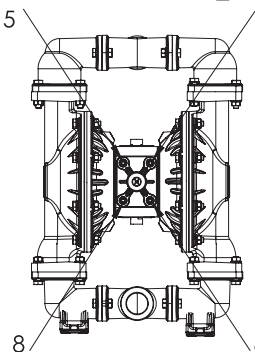

RIGHT-LEFT FLUID COVER

Tighten the bolts with 29N.m_33N.m torque

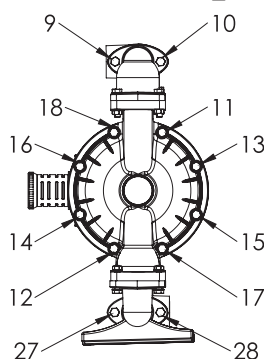

T ELBOW PART

Tighten the bolts with 28N.m_31N.m torque

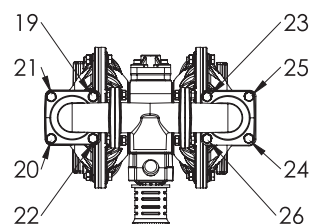

5- TERMS OF WARRANTY

VESTAPOMP grants warranty for elimination of material and workmanship faults caused by manufacturing of VESTAPOMP brand pumps as of the date of delivery of the pump to the final user. This warranty applies only when the equipment is installed, operated and maintained in accordance with VESTAPOMP's written recommendations.

This warranty does not cover general wear and tear, and VESTAPOMP/VESTAPOMP general wear and tear or faulty installation, faulty application, abrasion, corrosion, inadequate or improper maintenance, negligence, accident, unconscious maintenance or equipment not covered under the warranty of VESTAPOMP/VESTAPOMP: (hoses, connections, fittings, pneumatic regulator.) consumables such as diaphragms, check valve balls, ball seats and all the bolts (o-ring, z-ring) are not covered by this warranty.

It does not provide any warranty for accessories and equipment which are sold by VESTAPOMP but not produced by it, and rejects warranties for expired merchantability and eligibility for a certain intended use.

VESTAPOMP/VESTAPOMP shall not accept any compensation, loss, damage and injury responsibility whatsoever under no circumstances; does not accept any responsibility, liability, cost or expenditure that are directly or indirectly related to or occur due to use or non-functionality of any product; or VESTAPOMP/VESTAPOMP does not accept any responsibility or liability regarding direct, special, criminal or successive results including but not limited to sales loss, profit loss, pumped material loss, work slowdown, production loss, contract loss, reputation or goods or injury regardless of being notified or aware of the potential risks.

Sending the pump as completely drained and cleaned so as not to cause damage to the environment or the package with prepaid transportation means to VESTAPOMP or authorized services for verification of the fault of the equipment notified to be faulty constitutes a prerequisite for the warranty. Equipment shall be returned to the final user by means of prepaid transportation. If no material or labor faults are detected in the result of the examination of the equipment; the user shall be charge a reasonable repair price which may include parts, labor and transportation costs.

VESTAPOMP/VESTAPOMP website provides information on its literature and materials in its marketing and technical literature and materials, intended for defining performance under actual operating conditions of any product or at a time when it was used in special applications, they do not define warranty, and these declarations and data should not be relied in determination of compliance of the products for performance or special applications under actual operating conditions.

All decisions on inefficiency reason depend only on VESTAPOMP's discretion. Prior written approval of VESTAPOMP shall be obtained before returning any products for evaluation of warranty inclusion.

In any case, VESTAPOMP/VESTAPOMP responsibility regarding any single product shall be limited to original price paid for the product.

No VESTAPOMP/VESTAPOMP authorized distributor or any other person is authorized to make any amendment on product warranty, and bind VESTAPOMP/VESTAPOMP with any responsibilities or liabilities other than expressly specified herein.

Extended Product Warranty

Pumps manufactured under VESTAPOMP/VESTAPOMP pump brand, are warranted against labor and fabrication faults for 2 years as of invoice date.

Repair period of the pumps is 20 business days. Our Company is not responsible for the products not received within 60 days. The time elapsed in repair is within the warranty period. In case of any conflicts, the customer has liability to prove. 5 years : VESTAPOMP provides spare parts and labor availability warranty. 5-10 years: VESTAPOMP grants only availability of spare parts.

All written and visual data in this document reflect last product information current while they were printed. VESTAPOMP reserves the right to make amendment without making prior notification at any time.

VESTA

Makes life comfortable

Алматы (7273)495-231
Ангарск (3955)60-70-56
Архангельск (8182)63-90-72
Астрахань (8512)99-46-04
Барнаул (3852)73-04-60
Белгород (4722)40-23-64
Благовещенск (4162)22-76-07
Брянск (4832)59-03-52
Владивосток (423)249-28-31
Владикавказ (8672)28-90-48
Владимир (4922)49-43-18
Волгоград (844)278-03-48
Вологда (8172)26-41-59
Воронеж (473)204-51-73
Екатеринбург (343)384-55-89

Россия +7(495)268-04-70

Иваново (4932)77-34-06
Ижевск (3412)26-03-58
Иркутск (395)279-98-46
Казань (843)206-01-48
Калининград (4012)72-03-81
Калуга (4842)92-23-67
Кемерово (3842)65-04-62
Киров (8332)68-02-04
Коломна (4966)23-41-49
Кострома (4942)77-07-48
Краснодар (861)203-40-90
Красноярск (391)204-63-61
Курск (4712)77-13-04
Курган (3522)50-90-47
Липецк (4742)52-20-81

Казахстан +7(7172)727-132

Магнитогорск (3519)55-03-13
Москва (495)268-04-70
Мурманск (8152)59-64-93
Набережные Челны (8552)20-53-41
Нижний Новгород (831)429-08-12
Новокузнецк (3843)20-46-81
Ноябрьск (3496)41-32-12
Новосибирск (383)227-86-73
Омск (3812)21-46-40
Орел (4862)44-53-42
Оренбург (3532)37-68-04
Пенза (8412)22-31-16
Петрозаводск (8142)55-98-37
Псков (8112)59-10-37
Пермь (342)205-81-47

Киргизия +996(312)96-26-47

Ростов-на-Дону (863)308-18-15
Рязань (4912)46-61-64
Самара (846)206-03-16
Саранск (8342)22-96-24
Санкт-Петербург (812)309-46-40
Саратов (845)249-38-78
Севастополь (8692)22-31-93
Симферополь (3652)67-13-56
Смоленск (4812)29-41-54
Сочи (862)225-72-31
Ставрополь (8652)20-65-13
Сургут (3462)77-98-35
Сыктывкар (8212)25-95-17
Тамбов (4752)50-40-97
Тверь (4822)63-31-35

Тольятти (8482)63-91-07
Томск (3822)98-41-53
Тула (4872)33-79-87
Тюмень (3452)66-21-18
Ульяновск (8422)24-23-59
Улан-Удэ (3012)59-97-51
Уфа (347)229-48-12
Хабаровск (4212)92-98-04
Чебоксары (8352)28-53-07
Челябинск (351)202-03-61
Череповец (8202)49-02-64
Чита (3022)38-34-83
Якутск (4112)23-90-97
Ярославль (4852)69-52-93

vpo@nt-rt.ru || <https://vestapomp.nt-rt.ru/>

VPT5