

---

## INSTALLATION OPERATION MAINTENANCE

---

## GEAR PUMP MANUAL INSTRUCTIONS

---

Алматы (7273)495-231  
Ангарск (3955)60-70-56  
Архангельск (8182)63-90-72  
Астрахань (8512)99-46-04  
Барнаул (3852)73-04-60  
Белгород (4722)40-23-64  
Благовещенск (4162)22-76-07  
Брянск (4832)59-03-52  
Владивосток (423)249-28-31  
Владикавказ (8672)28-90-48  
Владимир (4922)49-43-18  
Волгоград (844)278-03-48  
Вологда (8172)26-41-59  
Воронеж (473)204-51-73  
Екатеринбург (343)384-55-89

Россия +7(495)268-04-70

Иваново (4932)77-34-06  
Ижевск (3412)26-03-58  
Иркутск (395)279-98-46  
Казань (843)206-01-48  
Калининград (4012)72-03-81  
Калуга (4842)92-23-67  
Кемерово (3842)65-04-62  
Киров (8332)68-02-04  
Коломна (4966)23-41-49  
Кострома (4942)77-07-48  
Краснодар (861)203-40-90  
Красноярск (391)204-63-61  
Курск (4712)77-13-04  
Курган (3522)50-90-47  
Липецк (4742)52-20-81

Казахстан +7(7172)727-132

Магнитогорск (3519)55-03-13  
Москва (495)268-04-70  
Мурманск (8152)59-64-93  
Набережные Челны (8552)20-53-41  
Нижний Новгород (831)429-08-12  
Новокузнецк (3843)20-46-81  
Ноябрьск (3496)41-32-12  
Новосибирск (383)227-86-73  
Омск (3812)21-46-40  
Орел (4862)44-53-42  
Оренбург (3532)37-68-04  
Пенза (8412)22-31-16  
Петрозаводск (8142)55-98-37  
Псков (8112)59-10-37  
Пермь (342)205-81-47

Киргизия +996(312)96-26-47

Ростов-на-Дону (863)308-18-15  
Рязань (4912)46-61-64  
Самара (846)206-03-16  
Саранск (8342)22-96-24  
Санкт-Петербург (812)309-46-40  
Саратов (845)249-38-78  
Севастополь (8692)22-31-93  
Симферополь (3652)67-13-56  
Смоленск (4812)29-41-54  
Сочи (862)225-72-31  
Ставрополь (8652)20-65-13  
Сургут (3462)77-98-35  
Сыктывкар (8212)25-95-17  
Тамбов (4752)50-40-97  
Тверь (4822)63-31-35

Тольятти (8482)63-91-07  
Томск (3822)98-41-53  
Тула (4872)33-79-87  
Тюмень (3452)66-21-18  
Ульяновск (8422)24-23-59  
Улан-Удэ (3012)59-97-51  
Уфа (347)229-48-12  
Хабаровск (4212)92-98-04  
Чебоксары (8352)28-53-07  
Челябинск (351)202-03-61  
Череповец (8202)49-02-64  
Чита (3022)38-34-83  
Якутск (4112)23-90-97  
Ярославль (4852)69-52-93

## TABLE OF CONTENTS

<b>INTRODUCTION</b> .....	<b>3</b>
<b>USING THIS MANUAL</b> .....	<b>3</b>
<b>HEALTH &amp; SAFETY</b> .....	<b>4</b>
<b>LIMITS OF USE</b> .....	<b>4</b>
<b>NOISE</b> .....	<b>4</b>
<b>PUMP INSTALLATION / MAINTENANCE</b> .....	<b>5</b>
<b>WORK ON ELECTRICAL EQUIPMENT</b> .....	<b>6</b>
<b>WORKING ON PRESSURISED SYSTEMS</b> .....	<b>6</b>
<b>INFORMATION ON VESTAPOMP PUMPS</b> .....	<b>7</b>
<b>DESCRIPTION</b> .....	<b>7</b>
<b>OPERATING PRINCIPLE</b> .....	<b>7</b>
<b>USING YOUR VESTAPOMP PUMP</b> .....	<b>8</b>
<b>SERIAL NUMBERS</b> .....	<b>9</b>
<b>STORAGE AND LIFTING OF GEAR PUMPS</b> .....	<b>10</b>
<b>STORAGE</b> .....	<b>10</b>
<b>LONG TERM STORAGE</b> .....	<b>10</b>
<b>LIFTING</b> .....	<b>12</b>
<b>INSTALLATION</b> .....	<b>13</b>
<b>GENERAL INFORMATION</b> .....	<b>13</b>
<b>DIRECTION OF ROTATION</b> .....	<b>14</b>
<b>BUILD CONFIGURATION</b> .....	<b>14</b>
<b>PIPING</b> .....	<b>15</b>
<b>CAVITATION</b> .....	<b>15</b>
<b>COUPLINGS</b> .....	<b>16</b>
<b>PUMP ALIGNMENT</b> .....	<b>17</b>
<b>EQUIPMENT INSTALLATION</b> .....	<b>18</b>
<b>TYPICAL INSTALLATION</b> .....	<b>18</b>
<b>OPERATING &amp; MAINTENANCE</b> .....	<b>19</b>
<b>PUMP START UP</b> .....	<b>19</b>
<b>PREVENTATIVE MAINTENANCE</b> .....	<b>20</b>
<b>STRIPPING, CLEANING &amp; REFITTING</b> .....	<b>21</b>
<b>SEALING METHODS</b> .....	<b>22</b>
<b>MECHANICAL SEALS</b> .....	<b>23</b>
<b>PACKED GLAND</b> .....	<b>24</b>
<b>LIP SEALS</b> .....	<b>25</b>
<b>RELIEF VALVES</b> .....	<b>26</b>
<b>SPARES &amp; REPAIRS</b> .....	<b>27</b>
<b>SPARES</b> .....	<b>27</b>
<b>REPAIRS</b> .....	<b>28</b>
<b>INFORMATION ON 'ALTERNATIVE' VESTAPOMP MODELS</b> .....	<b>28</b>
<b>TROUBLE SHOOTING</b> .....	<b>29</b>
<b>CONTACTS</b> .....	<b>31</b>

This manual contains general instructions for the storage, installation, operation and maintenance of an VESTAPOMP gear pump.

VESTAPOMP gear pumps are available in many configurations, whilst they may look the same, there may be differences from one pump to another, and therefore supplementary instructions can be supplied.

To get the best from the pump, carefully read and understand this manual before installation and start-up. VESTAPOMP cannot anticipate all of the situations a user may encounter while installing and using VESTAPOMP products. Therefore, the user of an VESTAPOMP product **MUST** know and follow all applicable industry specifications on the safe installation and use of these products.

VESTAPOMP will not be held responsible for any consequence due to the improper installation and use of the pump.

### *USING THIS MANUAL*

Read and understand the manual. Contact us if anything is not clear.

Keep the manual for the life of the pump.

If pump maintenance is necessary use this manual for safety and technical information.

For safe working, observe the operating and maintenance instructions for associated motors, engines, couplings and relief valves.

Personnel must understand and apply these precautions during both operating and maintenance of the pump. The user's attention is therefore drawn to the following:

1. The appropriate sections of this manual must be read before working on the equipment.
2. Installation and servicing must only be carried out by suitably trained or qualified personnel.
3. Normal safety precautions must be taken and appropriate procedures observed to avoid accidents

The following symbols are used throughout this manual to draw attention



*Warning – non compliance with this point could result in injury/harm*



*Refers to electrical safety points which can cause injury/harm*



*Cautions, Safe operation of pump*

---

### **LIMITS OF USE**



*The pump/pump sets must not be subjected to pressures and temperatures in excess of those for which it was originally quoted and supplied. It must not be subjected to extremes of temperature and/or humidity for which it was not designed.*

Never use heat to disassemble the pumps due to risk of explosion from trapped liquid. Never operate the pump without all guards correctly installed.

Never operate the pump beyond the rated conditions for which the pump was originally sold.

Never run the pump when dry.

Never operate the pump with discharge valve closed.

Never operate the pump with suction valve closed.

### **NOISE**

On certain installations, pump models and at certain operation points shown on the pump curves a noise level of 80 dB, can be exceeded

When working in a pump house check the noise. Above 70 dBA, wear ear defenders.

Above 85 dBA, wear ear defenders and limit your time working in this area.

Remove the pump to somewhere quieter to carry out any maintenance.

**PUMP INSTALLATION / MAINTENANCE**

Please install your pump in accordance with the latest National Safety Regulations.

Before working on an installed pump  
Hazardous liquid – drain and clean the system

- 1) Depressurise the pump and all lines
- 2) Disconnect the power supply. Lock it off.
- 3) Disconnect the shaft coupling

It is hazardous to:

Run the pump without the coupling guard fitted

- 1) Change the use of the pump or modify it without VESTAPOMP approval
- 2) Fail to maintain the pump, as this can cause injury or fire

The pump user is responsible for the safe use of the pump

Alterations to your pump are not allowed.



*Pumps can be dangerous if they are:  
incorrectly installed  
incorrectly used  
not serviced*



*Restrict access to the pump to competent people.*



*Use the correct tools for maintenance.*



*Lock off the electric starter; post a permit to prevent unauthorised starting.  
Switch off and isolate any electrical heating system.*



*Do not touch rotating parts.*



*Wear your PPE and goggles.*



*Assume that the pump is hot, check; allow to cool before starting work.*



*In the case of pumps for hot liquids allow to cool. Shut off all oil or steam heating systems, vent them when cool.*



*Consider whether the pump or its parts may topple over. Take care to avoid injury from falling parts, especially if the pump is large or heavy.*

***WORK ON ELECTRICAL EQUIPMENT***

Take extra care when working with any electrical equipment associated with the operation of the pump; check that the motor terminals are not live even after switching off the supply. Earthing - ensure the pump has a proper ground connection.



*Do not attempt any inspection or repair before disconnecting the pump set from the electric supply.*

*Where possible lock off the switch gear and post a permit on it, yourself. Test that the motor terminals are not live before starting work.*

---



*Do not work on wet equipment*

---



*Only use a qualified electrician*

---

Refer to original manufacturer of motor / engine for maker's installation manual.

***WORKING ON PRESSURISED SYSTEMS***

Check and observe the system pressure regularly.



*Liquids under pressure can cause injury, wear goggles and PPE*

---



*Vent all pressure containing parts to atmosphere, taking care in case the system is under pressure.*

---

First close all valves.

Bleed the pump and system; this includes any thermal oil heating system.

Take great care with toxic/hazardous liquids.

## INFORMATION ON VESTAPOMP PUMPS

### DESCRIPTION

The VESTAPOMP gear pump is an external gear positive displacement pump which consists of two counter-rotating shafts. The gears (rotors) which are attached to these shafts mesh together and rotate freely inside the pump casing bores.

The pumping rotors are contained within a rigid housing which is securely fixed together with mating faces being sealed by the use of a gasket (paper or liquid) or O-ring to prevent leakage of fluid under pressure.

The driving shaft of the pump which protrudes from the pump casing is sealed to prevent leakage of the pumped fluid by means of either a packed gland or lip seal (pressure relieved) or mechanical seal.

Drive to the pump is achieved via a prime mover (electric motor, engine etc.) being connected to the pumps drive shaft using a coupling. This unit is normally mounted on a combination bed plate.



*Guards can only be removed with the use of tools and must be replaced as soon as any work that requires the guard to be removed has been completed.*



*Guards are not designed to support any weight*

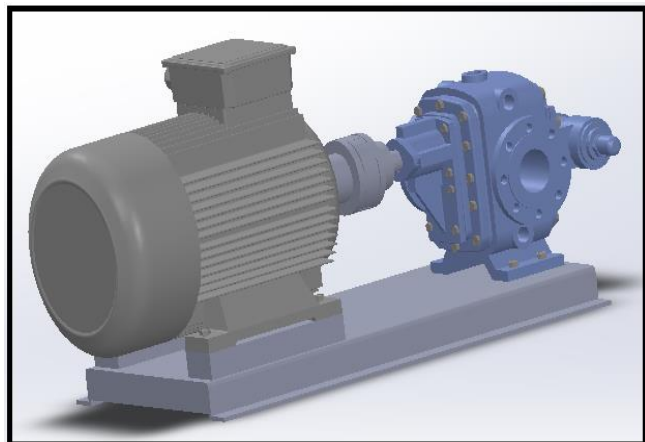
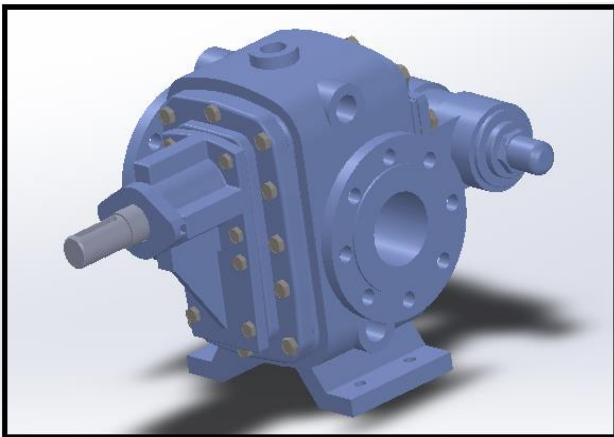

### OPERATING PRINCIPLE

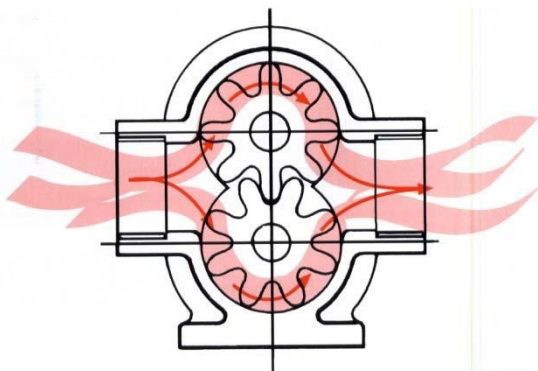

Liquid flows into the pump through the inlet (suction) branch (screwed or flanged connection); is carried round by the rotating rotors and pumped out of the outlet (delivery) port (screwed or flanged connection). Contact between the gear teeth separates and seals the suction side from the delivery side of the pump. This creates the vacuum which allows atmospheric pressure or a positive suction head to get the liquid into the pump. All the time the pump is rotating, liquid will be moved from the suction side to the discharge side.

***USING YOUR VESTAPOMP PUMP***

It is vital that the fluid passing through the pump is clean and free from abrasives or solids as damage to the pump could occur.

Pipe forces: design your system to absorb pipe movements due to heat. Exactly line up your pipes. Do not use the pump to support pipework.

Liquid pressure: fit gauges and check that the actual conditions are not worse than those VESTAPOMP supplied the pump for.

Heat: welding the pump can cause deformation. A seized pump can result.

Do not use hammers, instead use rubber or plastic mallets when needed. Castings can be brittle.

Changes to the duty, or the pump system: tell us in writing if you have to modify the duty or the system. Any un-approved change is the user's responsibility and can invalidate our warranty.



## INFORMATION ON VESTAPOMP PUMPS

### **SERIAL NUMBERS**

Please record the pump model and serial number, VESTAPOMP will need this information when you require parts or service, should any problems occur with the pump in its lifetime we have a spares and repair service. The use of genuine VESTAPOMP parts will provide the safest and most reliable operation of your pump. ISO certification and quality control procedures ensure the parts are manufactured to the highest quality and safety levels.

To help us identify the pump VESTAPOMP will need to know the pump serial Number which is stamped into the pump casing. Typical positions for serial number are shown below.

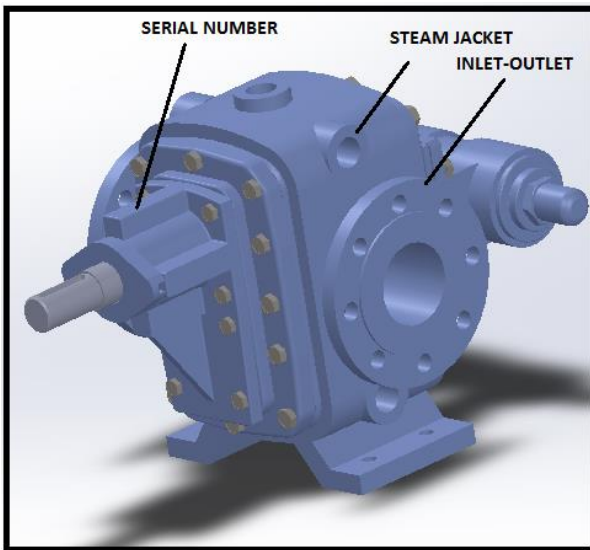

Type:			
Q:	m <sup>3</sup> /h	n:	D/D
H:	mss	DØ:	mm
P:	HP	P.Date:	
Serial No:			
<b>MADE IN TURKEY</b>			

## STORAGE AND LIFTING OF GEAR PUMPS

---

### **STORAGE**

Upon delivery of equipment, store in a covered and dry location. Store only in dust, and vibration free ambient temperature conditions. The transport packaging is not a suitable place for long term storage.

Pumps to be placed in storage should be coated internally with oil or a suitable preservative prior to storage.

Rotation of drive shaft by hand to circulate the preservative oil every 8 weeks is recommended. If the shaft has to be hand rotated occasionally to comply with the bearing manufacturer's recommendations, then the sealing faces of the mechanical seal should be coated with a light film of lubricating oil.

Mechanical seal clamping plate bolts can be loosened off approximately 2 to 3 rotations at the throat to relax the spring loading. The corresponding gap left between the stuffing box face and the gland plate should be masked to exclude dirt.

Check glands and seals for deterioration.

For pump units coupled to motors/engines refer to drive and coupling manufacturers for their storage procedures.

### **LONG TERM STORAGE**

Pumps that will not be installed for an extended period should be stored indoors, if possible. The factory installed port plugs will not ensure protection from excessive humidity, splash water or rain.

Care should be taken with motor and mechanical seals.

#### *Mechanical Seals:*

Pumps and other equipment subject to long term storage are best stored without the mechanical seal being installed. Seal installation should only then be carried out shortly before the actual start up of the unit.

The Seal chamber should be completely dry. The seal faces should ideally be assembled dry also.

If hydrostatic or acceptance testing is to be done by the equipment manufacturer, then the seal area must be flushed clean and totally dried afterwards.

Suction and discharge flanges are to be covered to exclude the ingress of dirt. Covers should be marked:

'DO NOT REMOVE UNTIL EQUIPMENT IS INSTALLED'.

The open area between the gland plate and shaft sleeve is to be masked to exclude dirt. All open parts in the gland, adaptor plate and stuffing box are to be plugged and sealed.

#### *Mechanical Seals – shelf life:*

Mechanical seals should be stored in accordance with international DIN 7716 and ISO 2230 standards. Brief outlines of the essential recommendations are:

All seals should be retained in the original packaging, in a dry, stable, elevated stores location with good air circulation and away from direct sunlight, dust, chemicals and vibrations. Ideally temperature range of -10 to +20 deg C and a humidity level below 65%.

If the above storage guide lines are met, the expected shelf life of seals with standard Nitrile,

## STORAGE AND LIFTING OF GEAR PUMPS

### *Oil seals:*

Rubber oil seals should, wherever possible, be stored in a relaxed condition free from tension, compression or other deformation. If it is impossible to avoid deformation it should be kept to a minimum since deformation can lead to cracking and permanent change of shape. Where articles are packed in a strain-free condition they should be stored in their original packaging. Rubbers should be protected from strong sunlight and strong artificial light with a high ultra-violet content.

Rubbers should not be allowed to come into contact with solvents, oil, greases or any other semi-solid materials at any time during storage

Lip type seals should always be stored in such a way as to prevent the sealing edges being damaged. On no account should identity labels be tied to the actual components.

If the items are carefully stored as recommended their shelf life is generally very long., but in any case every detail should be tested immediately before assembly.

### *Electric Motor:*

#### 1. Bearings – Static Indentation

Motors should be stored in an area free from any source of vibration since this can cause premature bearing failure due to static indentation. Motor shafts should be rotated weekly by hand, insuring they are left in different positions.

#### 2. Lubrication

Motor bearings are lubricated at the factory for the shelf life of the grease (approx 4 years).

#### 3. Condensation

Motors should be stored in a warmed, ventilated store to minimise the risk of condensation.

- a. Motors provided with drain holes - The drain holes should be kept open and clean. In storage, the motors should be stood such that the drain holes are the lowest point so that any condensation, which does form will escape.
- b. Motors without drain holes – Provided that the environment is warmed and ventilated, no action is necessary, although a periodic insulation test is advisable (approx 3 monthly) to ensure it is maintained above 1 megohm. If motors are to be used or stored in cold and/or damp environments, we recommend the fitting of anti-condensation heaters – the heaters should be permanently energised if stored in this condition. N.B Heater circuit to be isolated before inspection.

Periodically, the insulation resistance to earth should be checked using a 500 volt insulation tester.



---

**IF IN A HAZARDOUS AREA USE AN 'EX' MEGGER.  
DO NOT USE A TEST VOLTAGE IN EXCESS OF 500 VOLTS.  
DO NOT APPLY TEST TO THERMISTORS (IF FITTED)  
(When checking for continuity of thermistors, voltage must not exceed 6V)**

---

If the insulation resistance has fallen below 1 Megohm, the motor will need to be dried out.

It is preferable to dismantle the motor to the point where the rotor can be removed. However, this is not essential; the drying process will simply take longer.



---

**NOTE: NO HAZARDOUS AREA MOTOR SHOULD BE DISMANTLED BY PERSONS OTHER THAN THOSE AUTHORISED TO DO SO. UNAUTHORISED DISMANTLING/ASSEMBLY MAY INTRODUCE THE RISK OF EXPLOSION DUE TO INCORRECT ASSEMBLY AND WILL INVALIDATE THE MOTOR CERTIFICATION.**

---

## STORAGE AND LIFTING OF GEAR PUMPS

### LIFTING

If connected, remove suction and discharge hose and piping before attempting to lift the pump.

Take care when moving the pump. Rough treatment or lifting in an unsuitable way may cause permanent damage.



*All operations must be carried out by properly trained personnel.*

*Use the lifting points provided. Do not lift pump sets using the motor lifting lug. Recommended hand lift is 21 kg (44 lbs) below shoulder, but above ground level. The pump should never be lifted by the shaft end.*

*Before lifting the pump set, check the weight from the delivery note.*

*Be careful when moving pumps. Lifting equipment must be able to adequately support the entire assembly.*

### Lifting Points

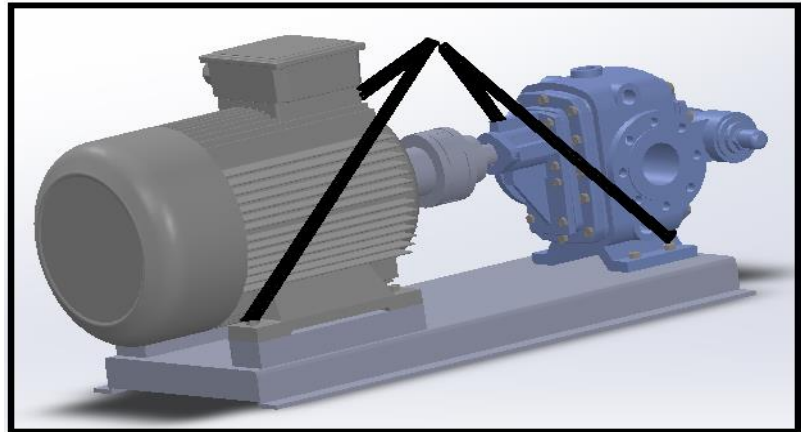
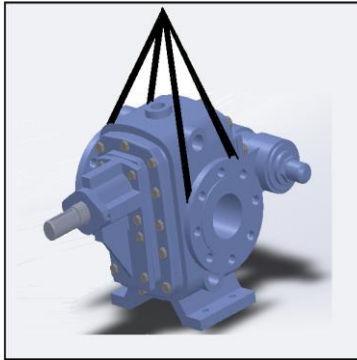

Most pumps below size NDP-6 are under the safe hand lift weight of 21kgs.

Standard bareshaft pump weights approximate (kg):

NDP-1,ND-2, NDP-3	10-15
NDP-4 , NDP-6	20
NDP-10	25
NDP-15 ,NDP-20	60
NDP-30	80

NDP-50	110
NDP-75	170
NDP-100	200

--	--



*Lifting motors: check that the eyebolt is fully screwed in. Do not use this eyebolt to lift the complete pump set.*

### GENERAL INFORMATION



*Please refer to the Health & Safety section of this manual before any work is carried out.*



**THE INSTALLATION MUST BE CARRIED OUT ONLY BY TRAINED PERSONNEL**



*All electrical work should be carried out by qualified personnel. Refer to the Electric Motor instructions regarding installation.*

Motors: Refer to original manufacturer of motor for maker's installation manual.

VESTAPOMP pumps must only be used to pump clean liquids. This will avoid wear or seizing of the rotors.

A pump should be located near the supply of liquid and have adequate space for operation, maintenance, and inspection. Leave space for lifting equipment to be used.

### **NOISE**

The installation of pump sets must be on solid foundations. Mounting pump sets on welded stands amplifies sound pressure levels which may then be too high. Inadequate support of pipe work can also increase noise levels. If noise exceeds locally permitted levels the fitting of sound proof enclosures or rubber mountings is recommended.

Noise levels will be above 75 dBA and will usually be in the 80 – 90 dBA range

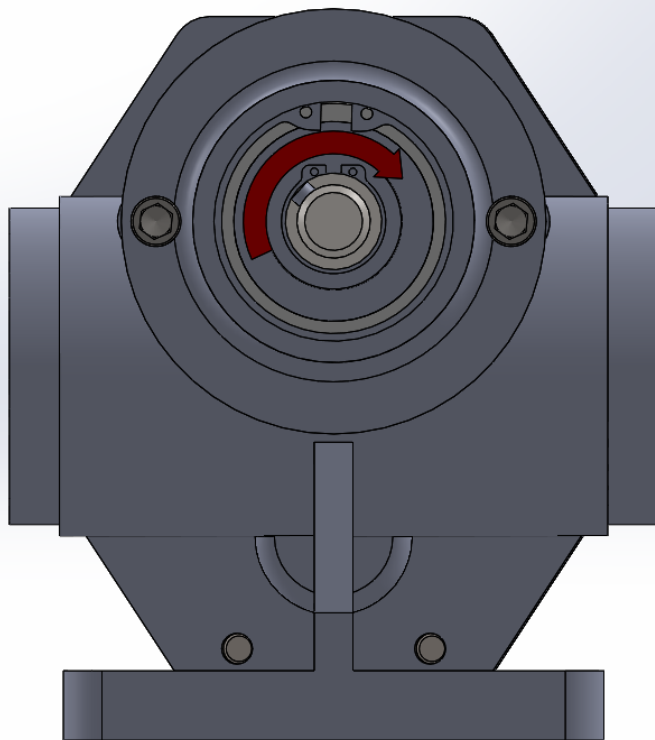
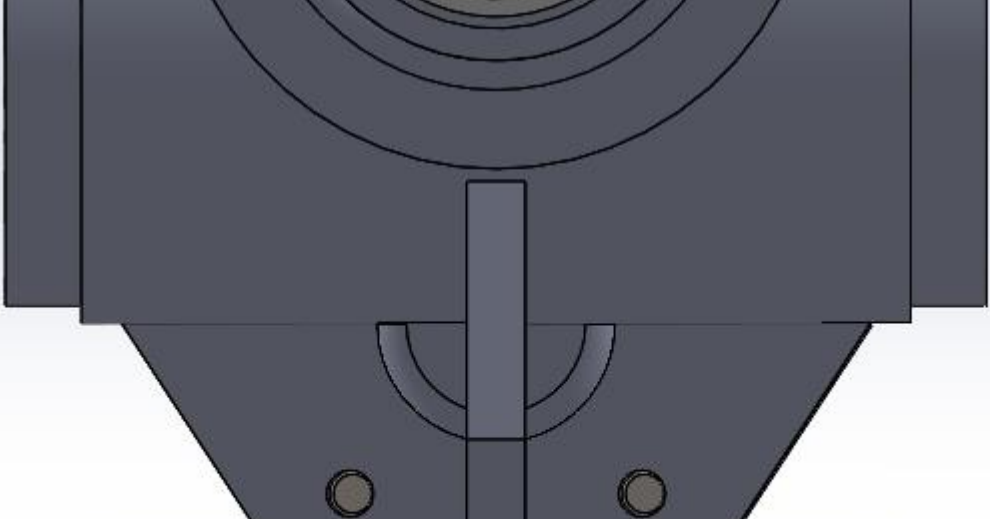

clockwise  
to Left

DE



clockwise  
FLOW FROM LEFT TO RIGHT

SUCTION

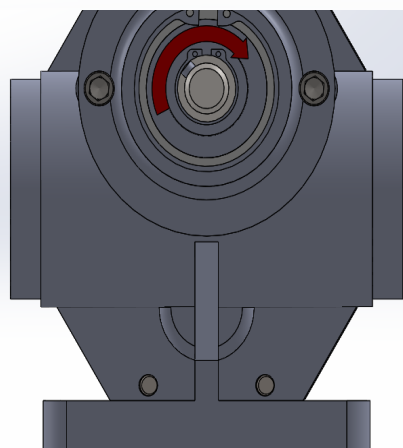

DELIVERY

## PIPING

The pipes connected to the pump should always be supported as close as possible to the pump in order to avoid stress in the pump casing. Axial movement of the pipe must not be allowed to be transferred to the pump housing as this may cause the pump to seize.

Flush the pipes and system or consider using a temporary filter to guard against welding slag etc. at start up.

Suction and delivery piping leading to and from the pump should never be smaller in diameter than the branches of the pump. In many cases i.e. where the length of piping is excessive or when the liquid is viscous, it will be necessary to use larger bore piping. Sharp bends and elbows should always be avoided where possible and never fitted near the pump branches. Pump connections when not flexible must always be brought into true line with the pump branches and externally supported otherwise strain and mal-alignment will result.

Suction and delivery branches are either flanged or screwed. When the unit has screwed branches

To avoid solids, keep the inlet (suction) pipe 100 – 200mm above the bottom of your tank. Use a coarse strainer in case of suspended debris.

Fit a pressure and a vacuum gauge not more than the equivalent in length of 4 diameters from the pump branch.

Most VESTAPOMP gear pumps are delivered with an internal relief valve. Our valves can be supplied for external relief in order to pipe the by-passed liquid back to tank to prevent the liquid heating up.



*Always use a relief valve if there is any chance of running the pump against a closed valve in the pipe work*

---

## Cavitation

Cavitation is usually caused by too high a vacuum in the suction line. Cavitation is recognised by a crackling sound in the pump, it occurs when small vapour bubbles form in the liquid as result of a local pressure drop within the pump which will cause a reduction of flow, and damage to pump internals.

Pumps need their inlets to be under a greater pressure than the vapour pressure of the liquid (at the pumping temperature). Especially with solvents or hot liquids, design the layout of the pumps and pipes to avoid suction problems. High viscosity causes greater pressure drops in the suction system; vapour pressure becomes greater with a rise in temperature.

*Suction pipes:* use materials which will not collapse under vacuum. Use the best air tight fittings and joints. It is important no air is sucked in to the pump as it will reduce the performance of the pump, in some cases the pump will stop pumping.

Where a high lift is required (about 3-4M or greater), fit a good quality foot valve to the suction pipe.

### **COUPLINGS**

The coupling is a device that provides connection between the pump and the drive. There are two main types of coupling used by VESTAPOMP, these being flexible and spacer type.

#### Flexible Type:

Semi-elastic couplings designed for general purpose use permit quick and easy assembly by means of taperlock bush fixing.

The flexible coupling consists of two hubs and a rubber central piece (spider), within each hub is a bush fixed by a taper.

This type of coupling has self centering shaft bushes and allows some misalignment without damage.

#### Spacer Type:

Where specified we fit spacer couplings (Metastream or equivalent)

This type of coupling is of rigid design and consists of two hubs and a spacer.

These couplings need to be very accurately aligned. We use a laser alignment machine to align the pump set before test at our works.



***DO NOT*** use undue force to fit the coupling halves on to the motor or pump shaft.  
*Damage can result leading to a shorter service life.*

---



### **PUMP ALIGNMENT**

Pumps direct coupled to motors / engines on bedplates are accurately aligned at our Works before despatch. It is essential that this alignment is maintained when the unit is installed and the pipe work connected. If there is any doubt carefully check after installation. Undue force in fitting pipe work can cause serious damage to the pump flange.

Most pumps are fitted with Fenner HRC flexible couplings. A flexible coupling is not designed to absorb misalignment.

Check for –

**Parallel misalignment** – shafts are inline angularly and parallel to each other, but are off-set.

This is checked by placing a short rule or straight edge on the coupling hub outside diameters. Check top/top and side/side and move or shim motor and pump as required.

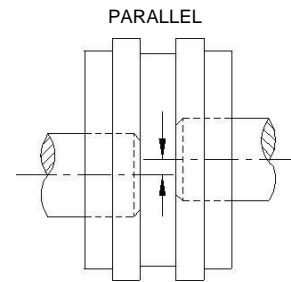

**Axial Misalignment** – includes impicalional 'end float', Shafts move axially increasing or decreasing the distance between shaft ends.

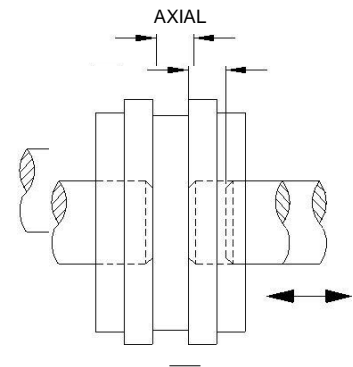

**Angular misalignment** – shafts are at an angle to one another. Make sure that the hub faces are parallel by checking top/top and side/side with callipers.

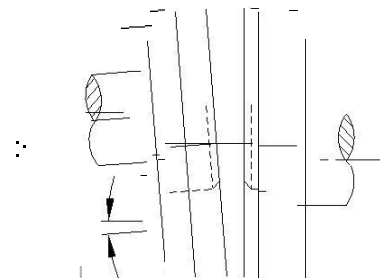

Allowable errors are:-

Coupling Type / Size	Maximum Misalignment		
	Parallel	Axial	Angular
Fenner HRC 70, 90, 110	0.3mm	+0.2, +0.5, +0.6mm	1.0 degree
Fenner HRC 130 150, 180	0.4mm	+0.8, +0.9, +1.1mm	
Fenner HRC 230, 280	0.5mm	+1.3, +1.7mm	
Metastream TSK13	± 0.3mm	± 1.0mm	0.5 degree
Metastream TSK33	± 0.35mm	± 1.3mm	

No pump, and particularly mechanical seal pumps, will give long service if they are out of alignment. A major misalignment will cause a shorter coupling life & increased bearing wear.

### EQUIPMENT INSTALLATION

Bedplate mounted pumps are normally grouted onto a concrete foundation, which has been poured on a solid footing. The foundation must be able to absorb any vibration and to form a permanent, rigid support for the pumping unit.

The pump set should be carefully lined up with the piping, the bedplate wedged after foundation bolts are grouted and the whole bedplate floated over up to the top of the bedplate lugs with well mixed grouting to ensure that the bedplate is quite solid and no springing possible.

After the concrete has dried install the pump set. Connect the pipes, re-check the coupling alignment (see pump alignment page), switch on the motor and check its rotation for an instant.

Prime the pump and pipe system (this is important where a mechanical seal is fitted). Check for leaks.

Fit any mechanical seal flushing/cooling pipes if required (see our General Arrangement drawing and quotation).

### TYPICAL INSTALLATION

- 1 Tank
- 2 Pipe Support
- 3 Suction Isolation Valve
- 4 Pipe Coupling / Union
- 5 Filter
- 11 Valve

- 6 Suction Pressure Gauge
- 7 Pump Unit
- 8 Discharge Pressure Gauge
- 9 Discharge Isolation Valve
- 10 System Relief Valve

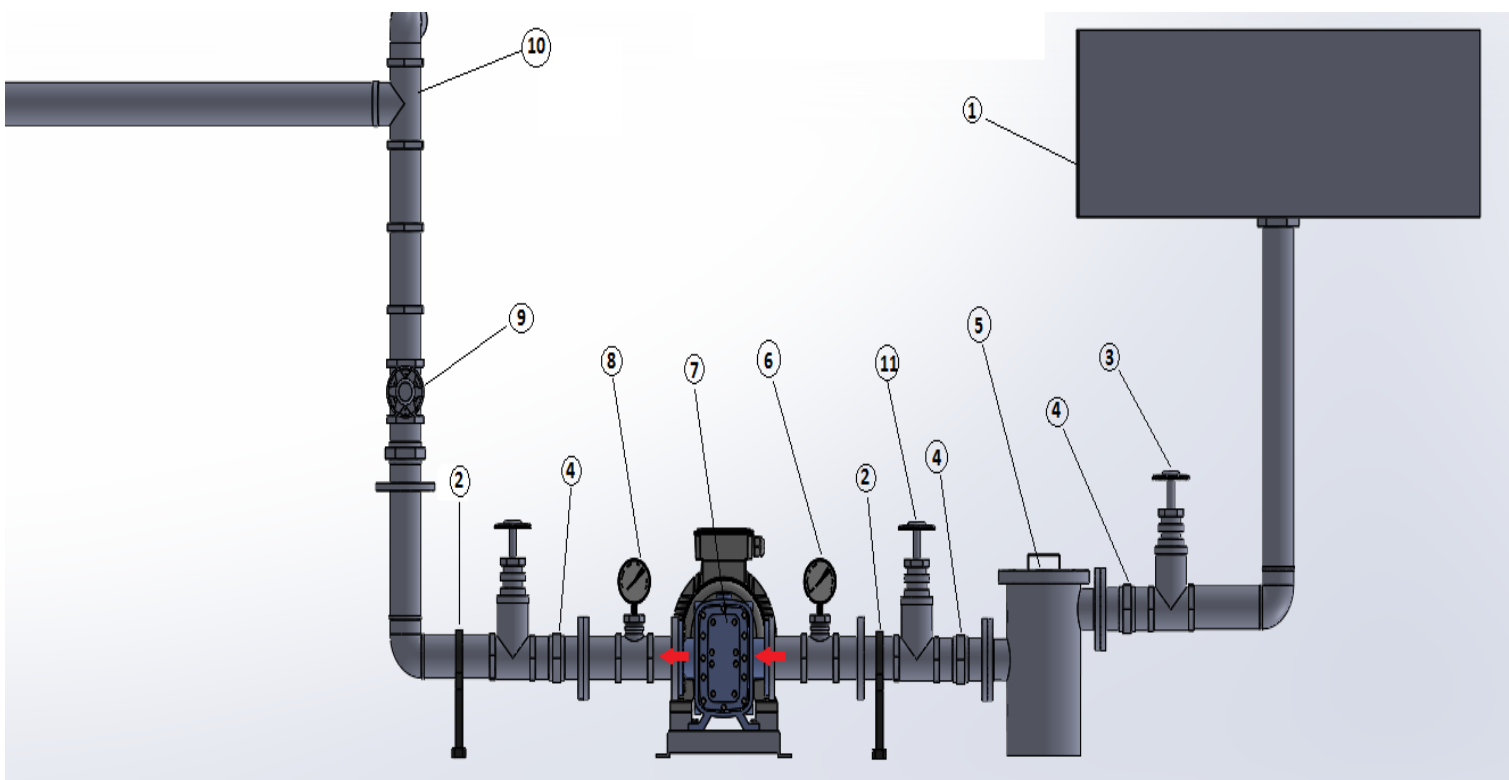

### **PUMP START UP**



*Refer to Health & Safety page of this manual before commencing work on pump*

---

Before start up procedure, make sure you have installed your pump correctly, checked coupling alignment, filled the pump with liquid and checked the rotation. The coupling guard should be in place.

1. Open all valves in the system and make sure that there are no obstructions in the circuit before starting the pump. Gear pumps must never be operated against closed shut-off valves.
2. Start the pump (making sure rotation is correct) and check that liquid is being pumped. In most applications an VESTAPOMP gear pump will self prime. If you have not primed the pump do not allow it to run dry for over 30 seconds. (Refer to our trouble shooting chapter). Please remember mechanical seals must not run dry.
3. All relief valves are factory set. If you have re-built your pump reset the relief valve to 10% over the maximum discharge pressure.
4. Check for leaks whilst operating at low pressure.
5. Watch/look/listen for excessive noise, vibration etc.
6. If all is well, SLOWLY increase the pressure to your requirement.
7. Check again for leaks.

If the pump should not immediately pump, or, according to the length of suction pipeline within, say 30 seconds. Stop the pump and prime it either through the charging plug provided or through the delivery pipeline. It should be noted on this subject that when the total lift exceeds 2.5 metres (8 feet), a foot valve should be fitted. For higher lift rather more priming is necessary.

It must be borne in mind that when liquids handled which give off vapour, the suction line to the pump must be flooded under as great a head as is possible, sufficient to overcome the vapour pressure. The NPSHA (*Net Positive Suction Head available*) must be greater than the NPSHR (*Net Positive Suction Head required*) of the pump.

### **PREVENTATIVE MAINTENANCE**

Pump applications are seldom identical, and pump wear is directly affected by such things as the abrasive qualities, pressure and temperature of the liquid being pumped.

Regardless of the application however, following a routine maintenance program can extend the life of your pump. Well maintained equipment will last longer and require fewer repairs. You should keep maintenance records; this will help pinpoint potential causes of problems.



*Refer to Health & Safety pages of this manual before commencing work on pump*

---



*The maintenance must be carried out by trained personnel. VESTAPOMP service personnel have a Permit to Work, they are able to help prepare a Method Statement and a Risk Assessment.*

---



*Do not attempt any inspection or repair before disconnecting the pump Set from the electric supply.*

*Where possible lock off the switch gear or remote starters and post a permit on it, yourself. Test that the motor terminals are not live before starting work.*

---



*Flush and drain the pump before opening it. Take extra care if the pump is pumping hot liquids or used on aggressive or toxic liquid.*

---

**Lubrication:** Adequate lubrication is essential for a Rotary Gear Pump.

When the liquid being pumped is not a lubricant, grease lubricators can be provided and these should be filled with Shell Alvania Grease 2 or equal. The frequency of greasing the bearings depends on circumstances but too much is better than too little.

In most cases the pumped liquid is sufficient.

Where ball thrust bearings are used (mechanical seals for example) grease regularly, in accordance with the makers advice.

Routinely check that the pump is operating as normal.

- 1) Excessive noise and vibration
- 2) Excessively Hot bearing areas
- 3) Flush or product leaks
- 4) Mechanical seal leakage
- 5) Gland compression and heat
- 6) Check ball and roller bearings. Add grease at 2000 hrs, re-pack with new grease every 4000 hours.
- 7) Check pump capacity and pressure

Periodically – 6 months

- 1) Check pump bolting and connections. Check bedplate foundation bolts
- 2) Any lubrication? – check it
- 3) Check alignment
- 4) Check that all ancillary equipment is in working order
- 5) If pump has been idle check the shaft sealing , replace if required

### *STRIPPING, CLEANING & REFITTING*

---



*Refer to Health & Safety page of this manual before commencing work on pump.*

---

To strip & inspect the pump, remove the pump to a clean, light workshop.

Locate the pump serial number if spares are required.

Dismantle the pump and inspect the parts, check for signs of wear:-

- 1) In the gland area for packed or lip seal pumps.
- 2) On mechanical seal faces (care must be taken as ceramic seal faces are fragile)
- 3) In the shaft bearings: check shafts and bearings, particular attention is to be given to the following (driven) shaft.
- 4) On rotor end faces and outside diameters

Using caution, as some components may have sharp edges, clean the pump parts with a cloth soaked in fresh cleaning solvent, make sure all the parts are fully cleaned prior to fitting. Where lubrication is required prior to final assembly clean lubricating oil is to be used.

Refit the pump in a clean place.

Refit the pump into position, check for leaks and refit any mechanical seal flushing pipes

Ensure that all the coupling or gland guards have been refitted after checking the coupling alignment.

Remove electrical locks and permits and keep other personnel away when re-starting.

Check for flow rate and noise.

## SEALING METHODS

---

The shaft seal is often the most sensitive component in a pump as it must seal between a rotating shaft and the stationary pump housing. In general VESTAPOMP provides three types of shaft sealing:

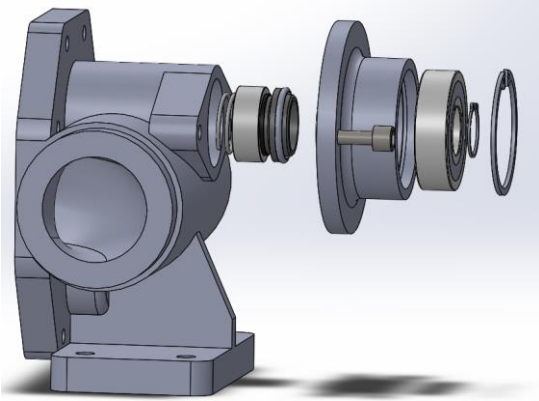

### **Mechanical Seal Design**

(picture shows optional thrust bearing)

The mechanical seals consist of two parts.

- 1) Rotary face assembly with spring(s) fixed to drive shaft
- 2) Stationary face mounted to the clamp plate

Seal faces are lapped to high standards of flatness. Mating materials are chosen for long life operation in the pumped liquid by VESTAPOMP and their seal supplier.

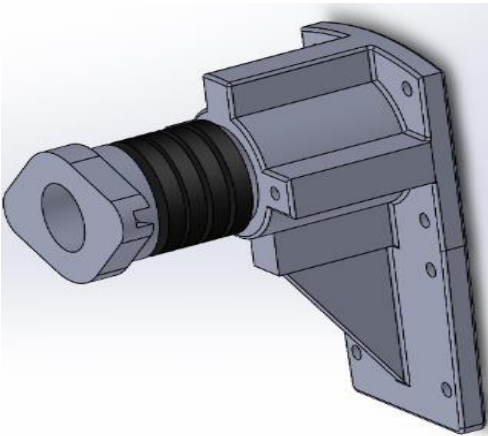

### **Packed Gland Design**

The packed gland seal is common form of shaft sealing for pumping applications.

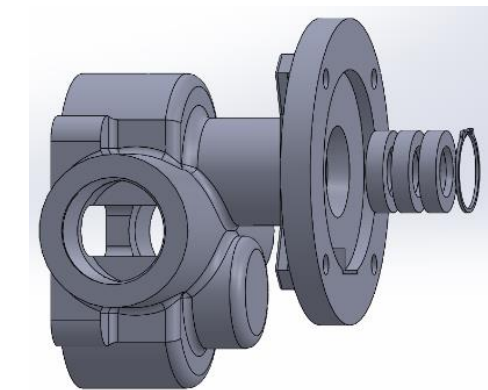

### **Lip seal Design**

Lip seals are usually used on flange mounted and Pelton wheel driven pumps. Cartridge fitted lip seal assemblies with hardened sleeves are available for certain liquids.

Lip seals retain the pumping liquid within the pump while keeping air, dust and dirt from entering along the rotating shaft.

**MECHANICAL SEALS**

In practice seals leak tiny amounts of liquid particularly at start up. This leakage helps prolong the seal life. Should leakage be forbidden due to the liquid’s toxicity etc. VESTAPOMP can fit double seals.

**Note:** The life of a mechanical seal depends on various factors such as cleanliness of liquid handled and its lubricating properties. Due to the variety of operating conditions it is, however, not possible to forecast its life.

**Single mechanical seal design**

Single seals are used on most hydrocarbon fluids of under 150°C as standard. We offer internal or external flushing, internal pressure reduction passages and heated or cooled seal housings as required by the application.

Do not use carbon faces on applications where viscosities over 2000cst may occur. Use a pinned seat on liquids of over 750cst.

**Seal maintenance**

Detailed maintenance and operation information is available from our mechanical seal manufacturers.

Mechanical seals should not be run dry. To avoid dry start up it is recommended that the pump cavity is filled with lubricating oil if possible or the duty fluid.

Check both faces for wear or damage.

Clean the housing, clamping plate and shaft.

Remove any keyway burrs or damage to the drive shafts before re assembly. Avoid damage to the new seal O rings or rubber bellows. Check the shaft, to make sure it is not bent.

Lubricate with light oil the faces and the shaft before carefully sliding the seal into the front cover of the pump.

After re-fitting the pump to the bedplate check the coupling alignment, misalignment shortens seal life. Refit all recirculation, quench or cooling pipes if fitted.

Re-prime the pump before start up.

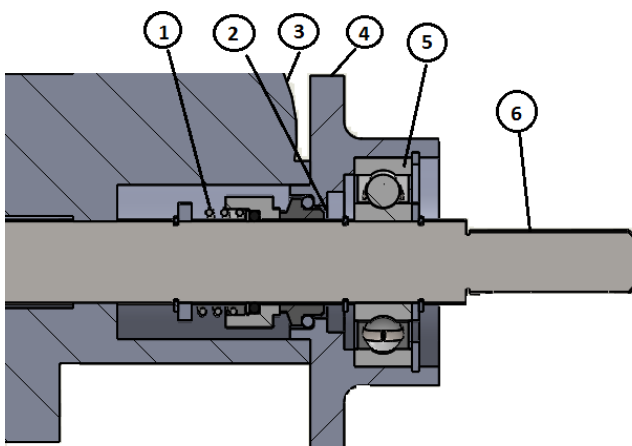

1	Rotary face assembly with spring
2	Stationary face
3	Gasket
4	Clamping plate
5	Thrust bearing (when supplied)
6	Shaft

**PACKED GLAND**

Packed gland sealing may require regular checks and maintenance adjustments. Proper lubrication of the gland packing requires a certain leakage rate. Gland packing manufacturer's recommendation's are to be observed. Service life expectancy is between 1 and 2 years, this can sometimes extend to several years in favourable conditions. Extremely bad fluid conditions (sediments, additives, overheating) can however drastically cut short gland service life.

**General Gland Maintenance**

- 1) Remove **all** old packing rings, check the number of rings
- 2) Always check that the shaft is not scored or grooved before repacking. If damage is found it will be hard to prevent early leakage without replacement of the shafts,
- 3) When re-packing stagger the joints by 120° replacing any lantern rings in their correct positions in relation to the flush holes.
- 4) Re-assemble the gland and tighten the nuts, about hand tight. Start the pump. After the pump has been running for 10 minutes with steady seepage, tighten the gland nuts by one sixth of a full turn. Tighten the gland nuts at ten minute intervals, each time evenly, by one sixth of a full turn, until leakage is reduced to an acceptable level. When adjustment is completed, there should be a drip leakage from the gland, ensuring that the overheating does not take place. With careful running-in, leakage may virtually be eliminated, particularly under light operating conditions. Subsequent adjustments should be made in the same way when the equipment is operating at normal working temperature and pressure. Fairly frequent replacement of the gland packing is more economical than over tightening leading to the scoring and replacement of pump shafts.

At start up or after repacking, pressurise the stuffing box, ensuring air is not trapped. A packed gland must weep. Until steady seepage takes place, the gland may overheat. If this happens, the pump must be stopped and allowed to cool. When re-started, leakage should take place. If it does not, this operation should be repeated, gland nuts may need to be slackened a small amount.



*Overheating and fire risk can be caused by over tightening the gland or by failure to re-pack the gland when needed.*



*Glands need to be repacked as soon as the packing has been fully compressed.*

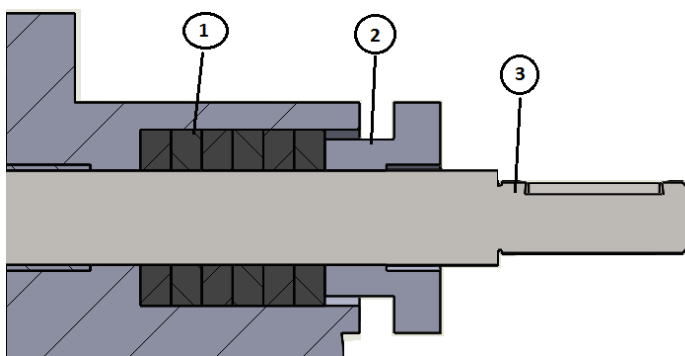

1	Seal Rings
2	Gland
3	Shaft



### LIP SEALS

In general, lip seals are more sensitive, than mechanical seals, to shaft run out and surface irregularities. A lip seal will often leak oil if the shaft has a total indicated run out of more than only a few thousands of an inch.

A lip seal pump is provided with an internal passage connecting the suction side of the pump to the seal chamber. These pumps cannot run in two directions without modification or special order. These pumps must not be subjected to a static head of more than 0.34 bar g. If the system this pump is fitted to has to be hydrostatically tested the pump must be isolated from the test. Failure to do this will blow the lip seal out.

### Maintenance

Lip seals require very little specific maintenance. The only normal maintenance they require is a sufficient amount of the correct type of lubricant. Since lip seals that protect a bearing installation are normally exposed to the bearing's lubricant, their lubrication is applied without any additional maintenance. Lack of lubrication may cause the seal's lip to directly contact the shaft, allowing friction to wear it away or tear it, causing leakage; Lubricants that are incompatible with the material type of the seal's flexible components can lead to chemical breakdown of those components. During maintenance/overhauling of equipment we strongly recommend that a new seal be fitted. Under no circumstances should the old seal be removed and then replaced in the same housing, the interference fit cannot be repeated.

Make sure that the sealing edge is not damaged in any way.

Check the shaft for wear/marks. Make sure that the area on which the seal is to run is in good condition.

Apply a liberal amount of clean grease or mineral oil to the sealing edge before offering the shaft back through.

Care must be taken to install the seal in the right direction. If replacing a previously used seal, be sure to note the direction, in which the primary lip of the old seal was facing, then ensure that the primary lip of the new seal faces the same way. Failure to orient the seal properly relative to the fluid being sealed will result in instantaneous leakage upon startup.

Normal practice is to wipe the edge of the seal that is to face the media to be sealed, and it is in this direction that it will hold against pressure.

**Shell Albida RL2** is recommended for use over the temperature range  $-20^{\circ}\text{C}$  to  $150^{\circ}\text{C}$  or

**AeroShell Grease 22** covers the operating temperature from  $-65^{\circ}\text{C}$  to  $+204^{\circ}\text{C}$ . (a fully synthetic grease designed for severe operating conditions).

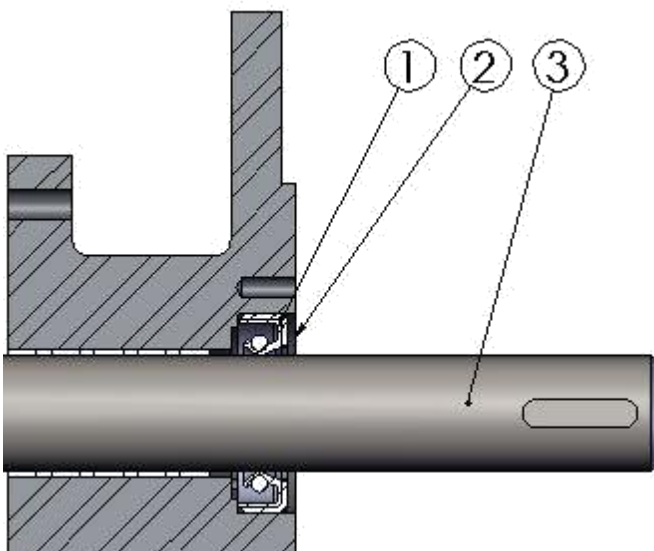

1	Lip seal
2	Circlip / Seal Cover Plate
3	Shaft

## RELIEF VALVES

VESTAPOMP normally has an option to supply an **internal** relief valve. These relief valves will temporarily relieve the pressure on the discharge side of a pump operating against a over excessive back pressure. They are normally not full ported, i.e. cannot by pass all the flow produced by the pump. These internal relief valves should be used for pump protection against a temporary over pressurization.

Relief valves are incorporated in the pump body and they are pre-set at our works to relieve either at a specified pressure or 10% above the working pressure. The pressure range is adjustable within certain limits by slackening the adjusting screw locknut and either by screwing the adjusting screw in to increase pressure or out to decrease pressure.

### **How it works:**

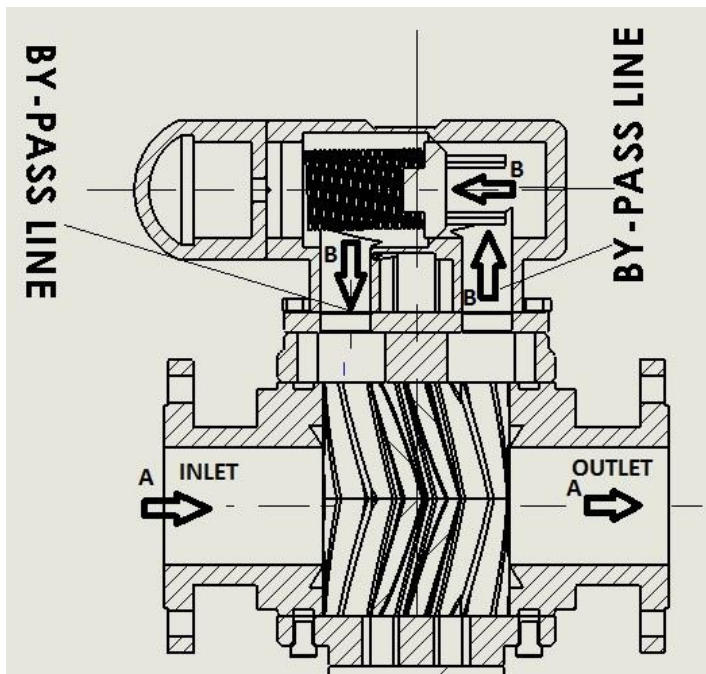

In the diagram normal flow is shown with arrow (A), the fluid flows through the pump suction and out of the delivery branch at the required pressure.

When the relief valve opens, due to a pressure build up, the fluid follows in direction of arrow (B)

Note: the diagram indicates the pumping flow of a Top- drive, Clock-wise right handed pump.

The valve is positioned on its seat and lapped in and the spring length is set during our test by use of the adjusting screw.

We can supply inbuilt or separate relief valves to return the excess liquid to tank.



*VESTAPOMP relief valves cannot be used as control valves or regulators for flow or pressure.*

Relief valves operate in one direction only.

If the pump is to operate in both directions of rotation, two separate relief valves will be needed.

Relief valve springs are available for a variety of pump pressures and overpressure ranges.

Dome caps are available for pumps with a high lift or a large positive suction head to prevent leakage or entry of air.

*The dangers of the pump going beyond its designed pressure limits are that it could*



result in an explosion or extreme damage to the pump components, the line itself and surrounding factors such as people.



Continual re-circulation of liquid through the relief valve causes overheating which can be dangerous in explosive atmospheres.

## SPARES

1	By-pass adjusting nut	6	Relief valve cover	11	Front Cover	16	Helical Gears	21	Seal housing
2	Adjusting Screw	7	Ball-Bearings	12	Front Cover Bolts	17	Driving shaft		
3	Spring	8	Back -Cover Bolts	13	Ball-Bearings	18	Gland box		
4	By-pass klape	9	Back -Cover	14	Helical Gear Fixing Screws	19	Bolts		
5	Relief valve bolts	10	Body	15	Idle Shaft	20	Shaft sealing		

To ensure the correct spares are supplied we need to know the pump serial number which is stamped into the metal of the pump body, or cover, in a prominent position on the top area of the pump.

Make sure that the correct spares are to hand before starting work on the pump. Contact our works if you need assistance before starting the job.

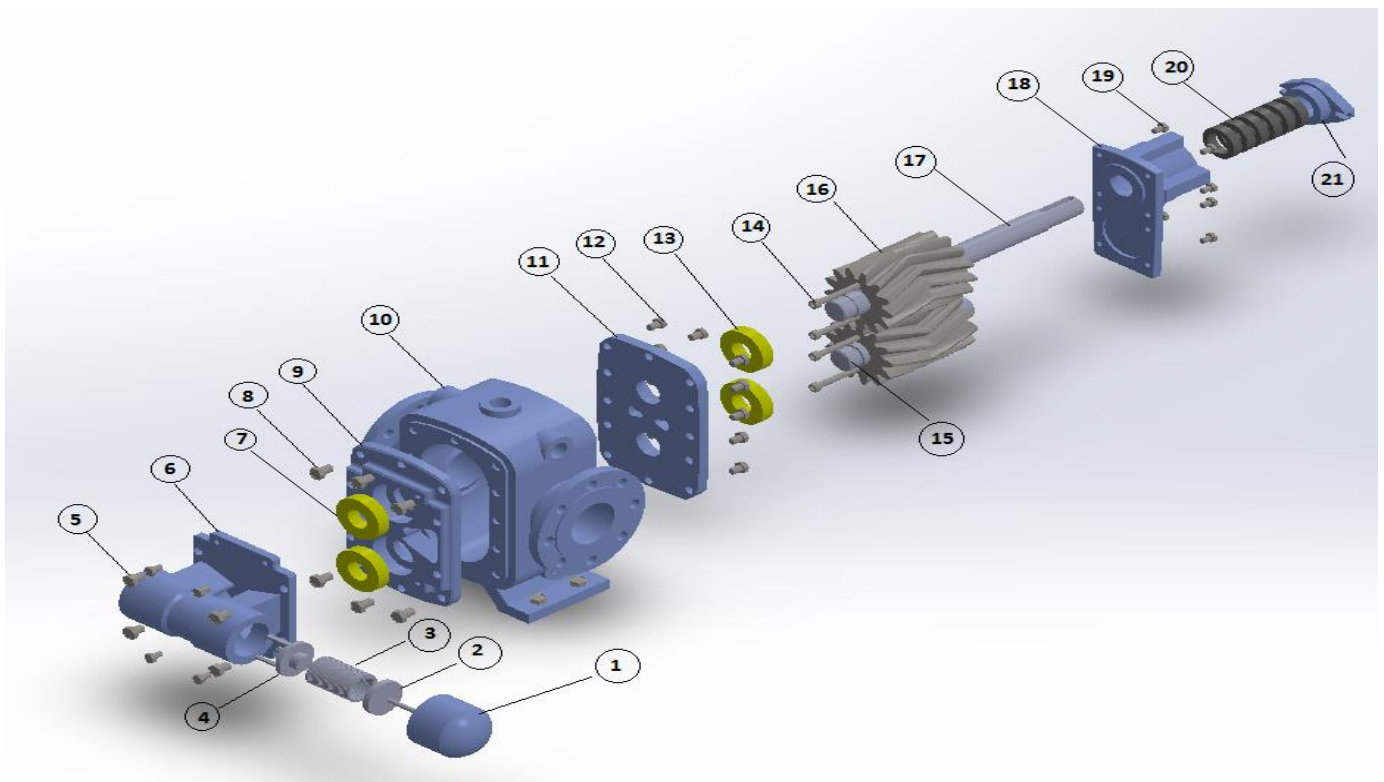

## REPAIRS

VESTAPOMP operates a repair service at our works and can quote for the repair of pumps returned to us for inspection.

Pumps returned for repair must be cleaned of the pumped fluid. Where the nature of the fluid is not disclosed to us a HAZARD RISK DOCUMENT CERTIFICATE must be supplied with the pump proving no hazardous substances are present meaning that the pump is safe to work on.

### Motor Repairs:

Use accredited competent engineers or repair shops. The user is responsible for the validity of Ex Certificates after repair.

## INFORMATION ON 'ALTERNATIVE' VESTAPOMP MODELS

---

**Superimposed Remote Bearings Pumps** are always provided with lubricators and these should be filled with Shell Alvania grease or equal. Pumps with remote bearings should be treated in the same way.

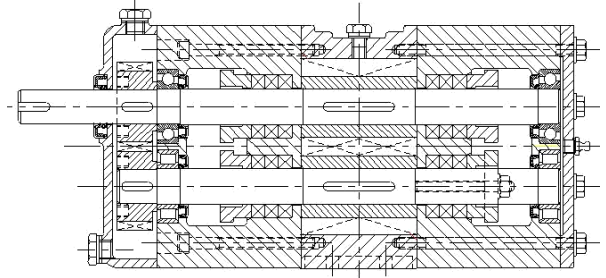

**Pumps With Ball and Roller Bearing lubricated by Product.** These pumps must only be used on filtered, non abrasive fluids with lubricating properties. Maximum temperature is usually 120°C.

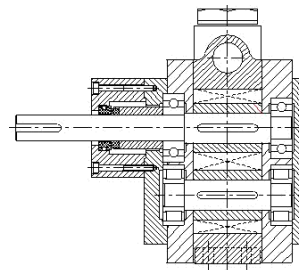

- 1 No liquid delivered:
  - (a) Pump not primed.
  - (b) Suction lift too high. Check with a gauge at the pump suction
  - (c) Wrong direction of rotation
  - (d) Pump not rotating (failure of drive from prime mover)
  - (e) Suction & Delivery pipes connected on wrong sides of pump
  
- 2 Not enough liquid delivered:
  - (a) Air leaks in suction or through stuffing box
  - (b) Speed too low
  - (c) Suction lift too high, or not enough suction head (for hot liquids)
  - (d) Foot valve too small or obstructed
  - (e) Foot valve or end of suction pipe not immersed deeply enough
  - (f) Piping improperly installed permitting air or gas to pocket in pump
  - (g) Mechanical defects:
    - Pump damaged
    - Pump badly worn
    - Packing defective
  - (h) Relief valve not seating or jammed by foreign matter.
  - (i) Relief valve set for too low a pressure.
  
- 3 Pump works for a while then loses suction:
  - (a) Leaky suction lines
  - (b) Suction lift too high
  - (c) Air or gases in the liquid
  
- 4 Pump takes too much power:
  - (a) Speed too high
  - (b) Liquid heavier or more viscous than we quoted for
  - (c) Suction or discharge line obstructed
  - (d) Mechanical defects
    - Shaft bent
    - Rotating element binds
    - Stuffing boxes too tight
    - Misalignment due to improper connection of pipe lines or driver
  - (g) Check pressure is being measured at the pump and not some distance away from the pump thus ignoring pressure losses in piping, valves, etc.
  - (h) Discharge pressure higher than quoted for.
  
- 5 Noisy pump:
  - (a) Speed too high
  - (b) Suction lift or viscosity too high (piping diameter too small) preventing filling of gear tooth spaces
  - (c) Wrong direction of rotation (Note: recesses in the pump covers to prevent hydraulic noise operate only in one direction)
  - (d) Badly supported pipes or bedplates causing resonant vibration. Rubber mounting can help.
  - (e) Relief valve chattering
  - (f) Pressure too low: an increase in pressure can prevent gear noise in low pressure applications
  - (g) Worn pump, check for wear

- 6 Excessive Gland leakage:
- (a) Packing hard and shafts scored
  - (b) Pressure on pump too high or pressure relief passage blocked
  - (c) Shaft run out excessive
  - (d) When repacking a gland all the old packing must be removed. It is not good enough just to add extra rings as the original packing becomes compressed
- 7 Excessive wear:
- (a) Abrasive liquid / Contaminated liquid
  - (b) Excessive speed
  - (c) Misalignment
  - (d) Excessive loading on drive shaft, axial or radial
  - (e) Pump is running dry
  - (f) Viscosity less than stated
- 8 Motor running hot and overheating:
- (a) Back pressure too great
  - (b) Incorrect supply voltage
  - (c) Motor phasing
  - (d) Pump operating outside temperature range
  - (e) Air temperature too high
  - (f) Motor covered in dust
  - (g) Electrical connections not correct for starting method
  - (h) Natural ventilation blocked
- 9 Pump overheating:
- (a) Re-circulating small amount of liquid
  - (b) Over tight gland
  - (c) Running dry
  - (d) Pump out of alignment

Алматы (7273)495-231  
 Ангарск (3955)60-70-56  
 Архангельск (8182)63-90-72  
 Астрахань (8512)99-46-04  
 Барнаул (3852)73-04-60  
 Белгород (4722)40-23-64  
 Благовещенск (4162)22-76-07  
 Брянск (4832)59-03-52  
 Владивосток (423)249-28-31  
 Владикавказ (8672)28-90-48  
 Владимир (4922)49-43-18  
 Волгоград (844)278-03-48  
 Вологда (8172)26-41-59  
 Воронеж (473)204-51-73  
 Екатеринбург (343)384-55-89

Иваново (4932)77-34-06  
 Ижевск (3412)26-03-58  
 Иркутск (395)279-98-46  
 Казань (843)206-01-48  
 Калининград (4012)72-03-81  
 Калуга (4842)92-23-67  
 Кемерово (3842)65-04-62  
 Киров (8332)68-02-04  
 Коломна (4966)23-41-49  
 Кострома (4942)77-07-48  
 Краснодар (861)203-40-90  
 Красноярск (391)204-63-61  
 Курск (4712)77-13-04  
 Курган (3522)50-90-47  
 Липецк (4742)52-20-81

Магнитогорск (3519)55-03-13  
 Москва (495)268-04-70  
 Мурманск (8152)59-64-93  
 Набережные Челны (8552)20-53-41  
 Нижний Новгород (831)429-08-12  
 Новокузнецк (3843)20-46-81  
 Ноябрьск (3496)41-32-12  
 Новосибирск (383)227-86-73  
 Омск (3812)21-46-40  
 Орел (4862)44-53-42  
 Оренбург (3532)37-68-04  
 Пенза (8412)22-31-16  
 Петрозаводск (8142)55-98-37  
 Псков (8112)59-10-37  
 Пермь (342)205-81-47

Ростов-на-Дону (863)308-18-15  
 Рязань (4912)46-61-64  
 Самара (846)206-03-16  
 Саранск (8342)22-96-24  
 Санкт-Петербург (812)309-46-40  
 Саратов (845)249-38-78  
 Севастополь (8692)22-31-93  
 Симферополь (3652)67-13-56  
 Смоленск (4812)29-41-54  
 Сочи (862)225-72-31  
 Ставрополь (8652)20-65-13  
 Сургут (3462)77-98-35  
 Сыктывкар (8212)25-95-17  
 Тамбов (4752)50-40-97  
 Тверь (4822)63-31-35

Тольятти (8482)63-91-07  
 Томск (3822)98-41-53  
 Тула (4872)33-79-87  
 Тюмень (3452)66-21-18  
 Ульяновск (8422)24-23-59  
 Улан-Удэ (3012)59-97-51  
 Уфа (347)229-48-12  
 Хабаровск (4212)92-98-04  
 Чебоксары (8352)28-53-07  
 Челябинск (351)202-03-61  
 Череповец (8202)49-02-64  
 Чита (3022)38-34-83  
 Якутск (4112)23-90-97  
 Ярославль (4852)69-52-93

Россия +7(495)268-04-70

Казахстан +7(7172)727-132

Киргизия +996(312)96-26-47