

TH SB BOOSTERS



General Information

It is high pressure, quiet running, compact and low power consumption.

SB pumps are suitable for pumping non-abrasive, clean or slightly contaminated, low viscosity liquids without solid & fibrous particles.

Vertical structure saves space.

Technical Data

Flow _____ up to 15 m³/h

Head _____ up to 120 m

Operating Temperature _____ 0 °C to 50 °C

Casing Pressure _____ 10 - 16 bar

Design Features

- TH SB booster is manufactured with horizontal or vertical pump.
- The boosters are produced as single, double and triple pumps as a standard according to the desired flow. Upon request, up to 6 pumps can be set.
- Single-pump boosters have a water level float (electric floater).
- Phase control system (PCS) is available in single pump, three-phase motorized boosters.
- Sequencing, phase control and liquid level control are standard features for multiple pumped booster pumps.
- Booster pumps can operate in two different modes; automatically and manually.
- Electrical materials used in the booster pump panels are selected from reliable and quality brands.
- The booster pumps can be manufactured as a variable-speed frequency control for convenience.

Material Equivalents

Part Name	Material	
	Standard	Optional
Pump		
Base Plate	GG 25	-
Stage Casing	NORYL	-
Intermediate Stage	NORYL	-
Impeller	NORYL	-
Shaft	AISI 420	-
Cover Plate	AISI 304	-
Panel	Pressure Switch Controlled	Frequency Controlled
Collector	Galvanized Steel	AISI 304
Frame	Galvanized Steel	-
Accessories		
Valve	Brass	-
Check Valve	Brass	-

Booster Designation

Booster Type _____

Number of Pumps _____

Pump Type _____

T : Three-phase M : Mono-Phase _____

Vertical Installation _____

Motor Building Size _____

Number of Stages _____

TH 1x SB T-V 80 /10

Алматы (7273)495-231
 Ангарск (3955)60-70-56
 Архангельск (8182)63-90-72
 Астрахань (8512)99-46-04
 Барнаул (3852)73-04-60
 Белгород (4722)40-23-64
 Благовещенск (4162)22-76-07
 Брянск (4832)59-03-52
 Владивосток (423)249-28-31
 Владикавказ (8672)28-90-48
 Владимир (4922)49-43-18
 Волгоград (844)278-03-48
 Вологда (8172)26-41-59
 Воронеж (473)204-51-73
 Екатеринбург (343)384-55-89

Россия +7(495)268-04-70

Иваново (4932)77-34-06
 Ижевск (3412)26-03-58
 Иркутск (395)279-98-46
 Казань (843)206-01-48
 Калининград (4012)72-03-81
 Калуга (4842)92-23-67
 Кемерово (3842)65-04-62
 Киров (8332)68-02-04
 Коломна (4966)23-41-49
 Кострома (4942)77-07-48
 Краснодар (861)203-40-90
 Красноярск (391)204-63-61
 Курск (4712)77-13-04
 Курган (3522)50-90-47
 Липецк (4742)52-20-81

Казахстан +7(7172)727-132

Магнитогорск (3519)55-03-13
 Москва (495)268-04-70
 Мурманск (8152)59-64-93
 Набережные Челны (8552)20-53-41
 Нижний Новгород (831)429-08-12
 Новокузнецк (3843)20-46-81
 Ноябрьск (3496)41-32-12
 Новосибирск (383)227-86-73
 Омск (3812)21-46-40
 Орел (4862)44-53-42
 Оренбург (3532)37-68-04
 Пенза (8412)22-31-16
 Петрозаводск (8142)55-98-37
 Псков (8112)59-10-37
 Пермь (342)205-81-47

Киргизия +996(312)96-26-47

Ростов-на-Дону (863)308-18-15
 Рязань (4912)46-61-64
 Самара (846)206-03-16
 Саранск (8342)22-96-24
 Санкт-Петербург (812)309-46-40
 Саратов (845)249-38-78
 Севастополь (8692)22-31-93
 Симферополь (3652)67-13-56
 Смоленск (4812)29-41-54
 Сочи (862)225-72-31
 Ставрополь (8652)20-65-13
 Сургут (3462)77-98-35
 Сыктывкар (8212)25-95-17
 Тамбов (4752)50-40-97
 Тверь (4822)63-31-35

Тольятти (8482)63-91-07
 Томск (3822)98-41-53
 Тула (4872)33-79-87
 Тюмень (3452)66-21-18
 Ульяновск (8422)24-23-59
 Улан-Удэ (3012)59-97-51
 Уфа (347)229-48-12
 Хабаровск (4212)92-98-04
 Чебоксары (8352)28-53-07
 Челябинск (351)202-03-61
 Череповец (8202)49-02-64
 Чита (3022)38-34-83
 Якутск (4112)23-90-97
 Ярославль (4852)69-52-93

Horizontal Tanked Boosters

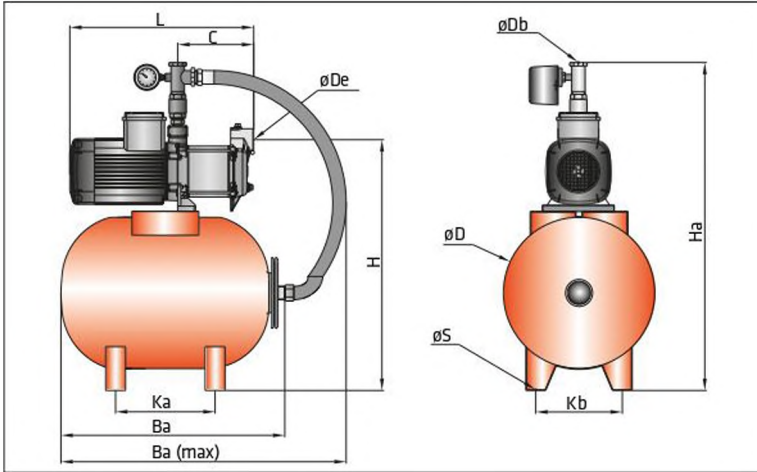

24 Tank	De	Db	Ba	Ba(maks)	H	Ha	Ka	Kb	L	C	øD	øS	KG
SBM 80/5-24	1 1/4"	1"	480	587	465	669	190	158	455	200	265	10	25,8
SBM 80/6-24									475	230			26,3
SBM 80/7-24									500	250			26,9
SBM 80/8-24									520	270			28,1
SBM 80/9-24									540	295			28,8
24 Tank	De	Db	Ba	Ba(maks)	H	Ha	Ka	Kb	L	C	øD	øS	KG
SBT 80/5-24	1 1/4"	1"	480	587	465	669	190	158	453	206	265	10	24,3
SBT 80/6-24									475	228			24,8
SBT 80/7-24									497	250			26,1
SBT 80/8-24									519	272			26,3
SBT 80/9-24									541	294			26,8
SBT 80/10-24									563	316			28,3
SBT 80/11-24	585	338	29										
50 Tank	De	Db	Ba	Ba(maks)	H	Ha	Ka	Kb	L	C	øD	øS	KG
SBM 80/5-50	1 1/4"	1"	600	696	565	779	220	232	453	206	280	10	31,7
SBM 80/6-50									475	228			32,2
SBM 80/7-50									497	250			32,8
SBM 80/8-50									519	272			34
SBM 80/9-50									541	294			34,7
50 Tank	De	Db	Ba	Ba(maks)	H	Ha	Ka	Kb	L	C	øD	øS	KG
SBT 80/5-50	1 1/4"	1"	600	696	565	779	220	232	453	206	380	10	30,2
SBT 80/6-50									475	228			30,7
SBT 80/7-50									497	250			32
SBT 80/8-50									519	272			32,2
SBT 80/9-50									541	294			32,7
SBT 80/10-50									563	316			34,7
SBT 80/11-50	585	338	35										
50 Tank	De	Db	Ba	Ba(maks)	H	Ha	Ka	Kb	L	C	øD	øS	KG
SBM 90/4-50	1 1/4"	1 1/4"	600	696	603	796	220	232	489	218	380	10	39,3
SBM 90/5-50									517	246			41,3
SBM 90/6-50									545	274			41,8
50 Tank	De	Db	Ba	Ba(maks)	H	Ha	Ka	Kb	L	C	øD	øS	KG
SBT 90/4-50	1 1/4"	1 1/4"	600	696	603	796	220	232	489	218	380	10	37,3
SBT 90/5-50									517	246			39,3
SBT 90/6-50									545	274			40,3
SBT 90/7-50									573	302			42,3
80 Tank	De	Db	Ba	Ba(maks)	H	Ha	Ka	Kb	L	C	øD	øS	KG
SBM 90/4-80	1 1/4"	1 1/4"	635	828	708	901	330	276	489	218	460	10	44,1
SBM 90/5-80									517	246			46,1
SBM 90/6-80									545	274			46,6
80 Tank	De	Db	Ba	Ba(maks)	H	Ha	Ka	Kb	L	C	øD	øS	KG
SBT 90/4-80	1 1/4"	1 1/4"	635	828	708	901	330	276	489	218	460	10	42,1
SBT 90/5-80									517	246			44,1
SBT 90/6-80									545	274			45,1
SBT 90/7-80									573	302			47,1
80 Tank	De	Db	Ba	Ba(maks)	H	Ha	Ka	Kb	L	C	øD	øS	KG
SBT 100/3-80	1 1/2"	1 1/2"	635	880	746	1007	330	276	530	219	460	10	51,3
SBT 100/4-80									563	252			52,8
SBT 100/5-80									596	285			58
100 Tank	De	Db	Ba	Ba(maks)	H	Ha	Ka	Kb	L	C	øD	øS	KG
SBT 100/3-100	1 1/2"	1 1/2"	820	940	746	1007	330	276	530	219	460	10	52,6
SBT 100/4-100									563	252			54,1
SBT 100/5-100									596	285			59,3

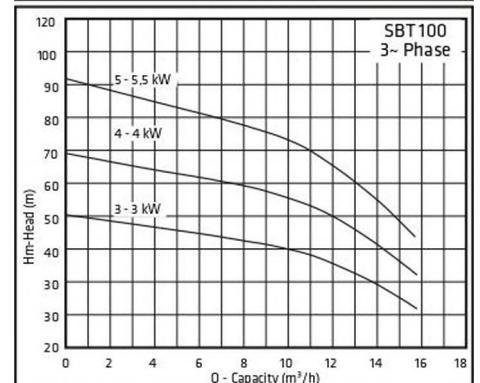
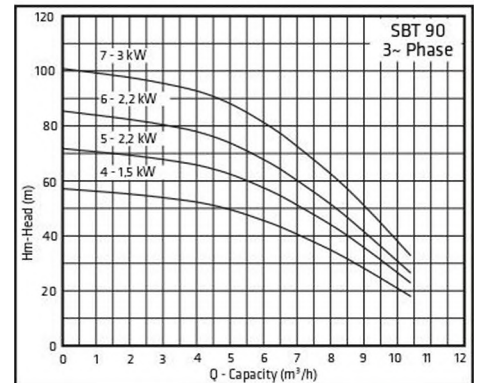
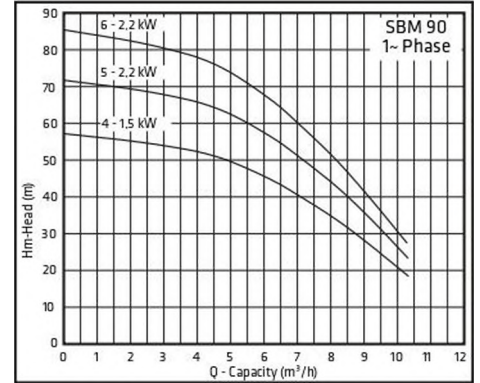
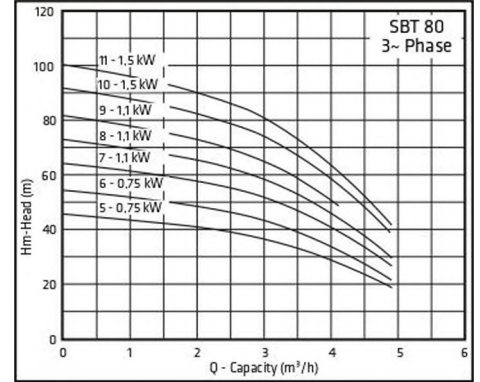
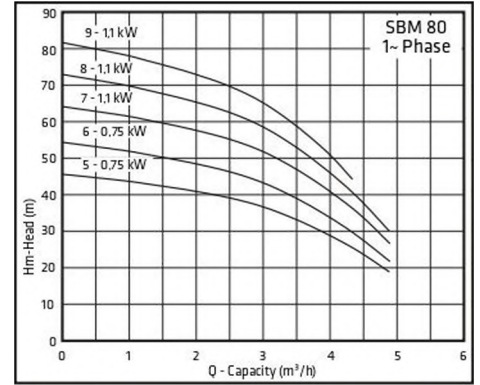

Booster set with one pump

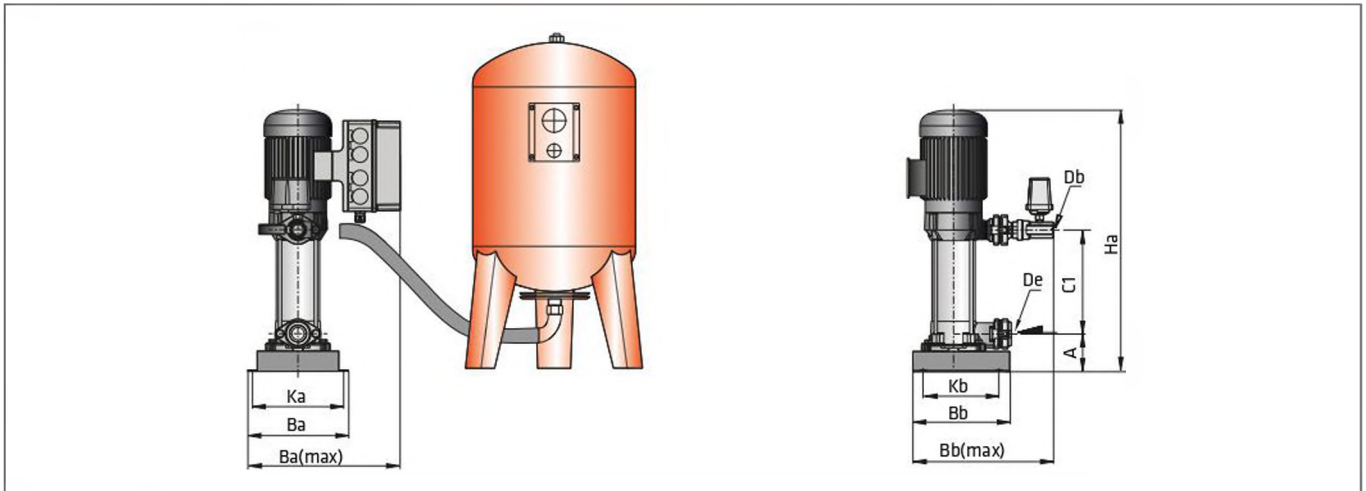

Booster set with two pump

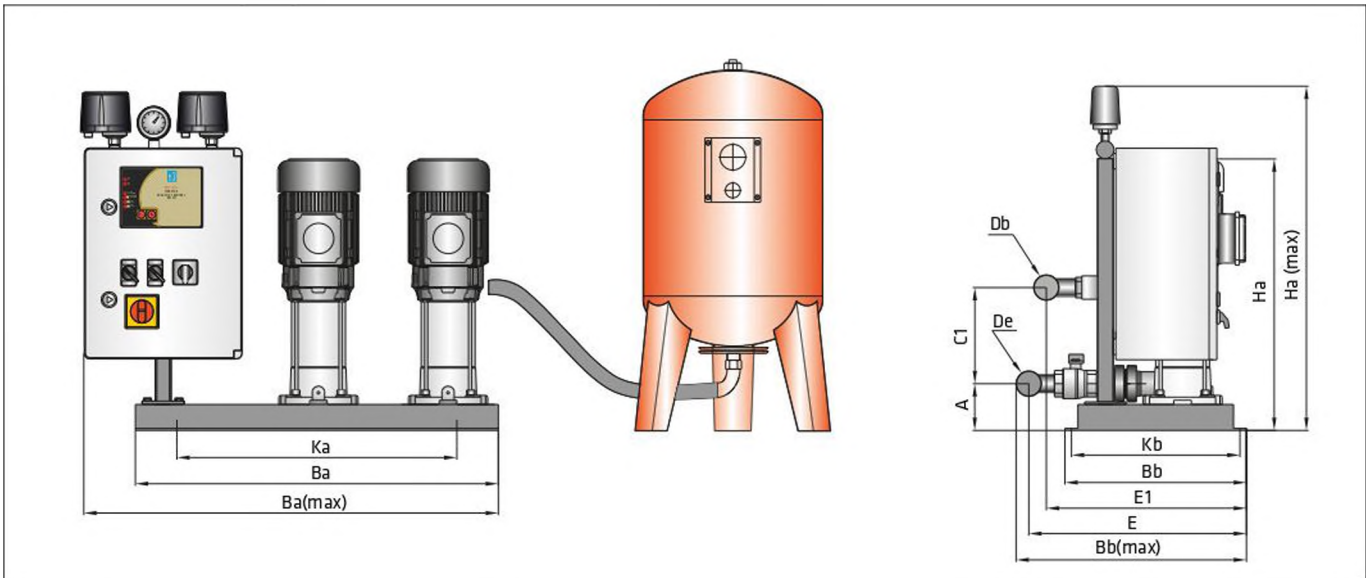

Booster set with three pump

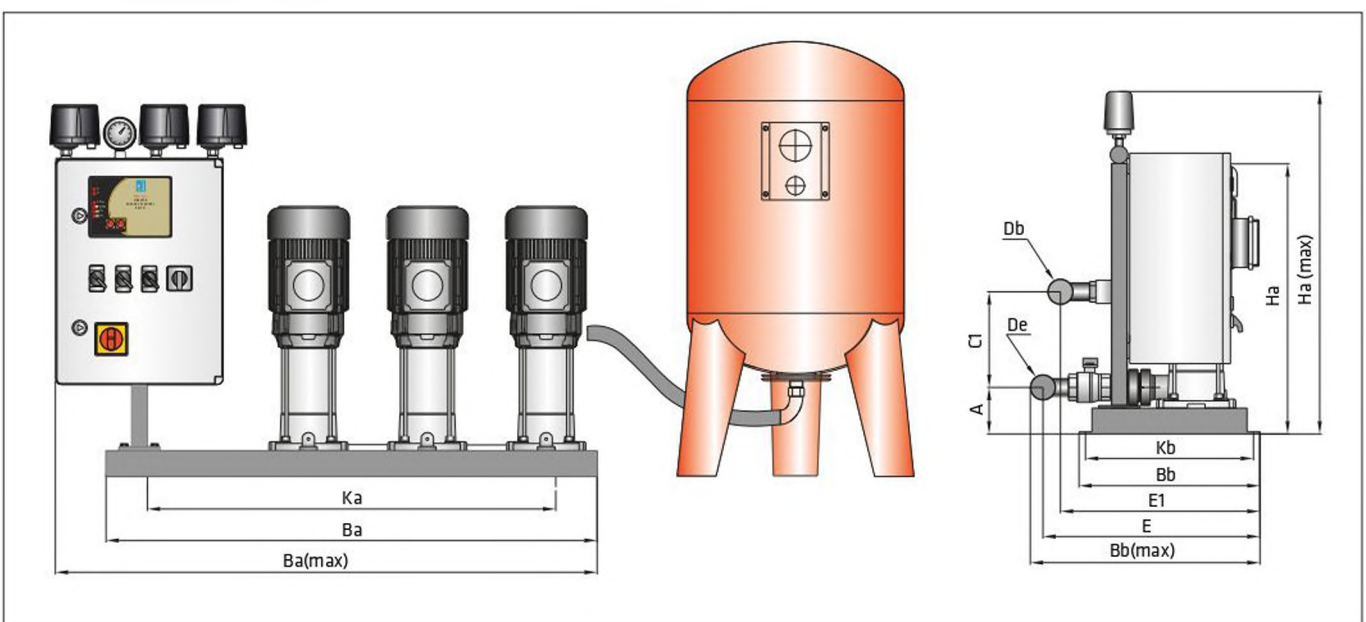

Performance Curves and Dimensions

TH SB

	De	Db	Ba	Bb	3a(max)	Bb(max)	Ha	Ha(max)	Ka	Kb	E	E1	A	C1	w
1xSBM-V 80/5	1 1/4"	1 1/4"	240	230	360	335	517	539	220	180	-	-	85	184	26,5
1xSBM-V 80/6							539	561						206	27
1xSBM-V 80/7							561	583						228	27,6
1xSBM-V 80/8							583	605						250	28,8
1xSBM-V 80/9							605	627					272	29,5	

	De	Db	Ba	Bb	3a(max)	Bb(max)	Ha	Ha(max)	Ka	Kb	E	E1	A	C1	w
1xSBT-V 80/5	1 1/4"	1 1/4"	240	230	360	335	517	517	220	180	-	-	85	184	25
1xSBT-V 80/6							539	539						206	25,5
1xSBT-V 80/7							561	561						228	26,8
1xSBT-V 80/8							583	583						250	27
1xSBT-V 80/9							605	605						272	27,5
1xSBT-V 80/10							627	627						294	29
1xSBT-V 80/11							649	649					316	30	
1xSBT-V 80/12							671	671					338	30,5	

	De	Db	Ba	Bb	3a(max)	Bb(max)	Ha	Ha(max)	Ka	Kb	E	E1	A	C1	w
2xSBM-V 80/5	1 1/4"	1 1/4"	700	350	825	445	522	753	630	320	420	390	90	184	66
2xSBM-V 80/6							544							206	67
2xSBM-V 80/7							566							228	69
2xSBM-V 80/8							588							250	71
2xSBM-V 80/9							610						272	72,5	

	De	Db	Ba	Bb	3a(max)	Bb(max)	Ha	Ha(max)	Ka	Kb	E	E1	A	C1	w
2xSBT-V 80/5	1 1/4"	1 1/4"	700	350	825	445	522	753	630	320	420	390	85	184	63
2xSBT-V 80/6							544							206	64
2xSBT-V 80/7							566							228	66,5
2xSBT-V 80/8							588							250	67
2xSBT-V 80/9							610							272	68
2xSBT-V 80/10							632							294	71
2xSBT-V 80/11							654						316	72,5	
2xSBT-V 80/12							676						338	73,5	

	De	Db	Ba	Bb	3a(max)	Bb(max)	Ha	Ha(max)	Ka	Kb	E	E1	A	C1	w
3xSBM-V 80/5	1 1/2"	1 1/2"	950	350	1085	460	522	810	880	320	430	400	90	184	97,5
3xSBM-V 80/6							543							206	99
3xSBM-V 80/7							566							228	101
3xSBM-V 80/8							588							250	104
3xSBM-V 80/9							610						272	106	

	De	Db	Ba	Bb	3a(max)	Bb(max)	Ha	Ha(max)	Ka	Kb	E	E1	A	C1	w
3xSBT-V 80/5	1 1/2"	1 1/2"	950	350	1085	460	522	810	880	320	430	400	90	184	93
3xSBT-V 80/6							544							206	94
3xSBT-V 80/7							566							228	98
3xSBT-V 80/8							588							250	99
3xSBT-V 80/9							610							272	100
3xSBT-V 80/10							632							294	105
3xSBT-V 80/11							654						316	107	
3xSBT-V 80/12							676						338	109	

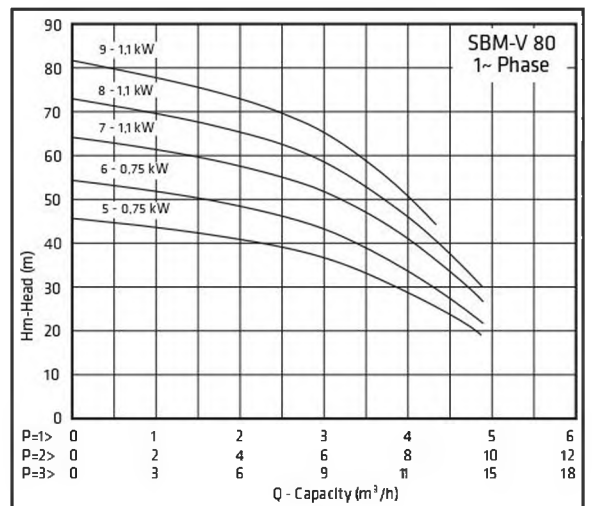
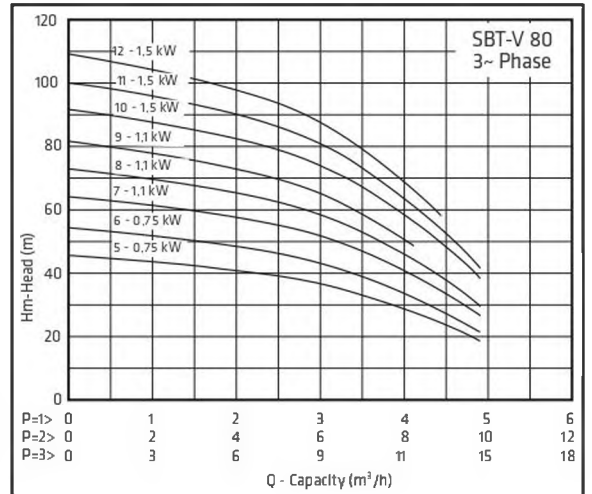

	De	Db	Ba	Bb	Ba(maks)	Bb(maks)	Ha	Ha(maks)	Ka	Kb	E	E1	A	C1	KG
1xSBM-V 90/4	1 1/4"	1 1/4"	245	230	360	354	544	544	225	180	-	-	85	188	34,5
1xSBM-V 90/5							572	572						216	36,5
1xSBM-V 90/6							600	600						244	37

	De	Db	Ba	Bb	Ba(maks)	Bb(maks)	Ha	Ha(maks)	Ka	Kb	E	E1	A	C1	KG
1xSBT-V 90/4	1 1/4"	1 1/4"	250	230	360	340	550							188	32,5
1xSBT-V 90/5							580							216	34,5
1xSBT-V 90/6							610	220	175	-	-	90		244	35,5
1xSBT-V 90/7							640							272	37,5
1xSBT-V 90/8							670							300	38
1xSBT-V 90/9							700							328	39

	De	Db	Ba	Bb	Ba(maks)	Bb(maks)	Ha	Ha(maks)	Ka	Kb	E	E1	A	C1	KG
2xSBM-V 90/4	1 1/2"	1 1/2"	700	350	822	450	550							188	76
2xSBM-V 90/5							578	753	630	320	400	432	90	216	84
2xSBM-V 90/6							606							244	85

	De	Db	Ba	Bb	Ba(maks)	Bb(maks)	Ha	Ha(maks)	Ka	Kb	E	E1	A	C1	KG
2xSBT-V 90/4	1 1/2"	1 1/2"	695	345	800	430	550							188	76
2xSBT-V 90/5							580							216	80
2xSBT-V 90/6							610	730	645	325	405	400	90	244	82
2xSBT-V 90/7							640							272	86
2xSBT-V 90/8							670							300	87
2xSBT-V 90/9							700							328	88

	De	Db	Ba	Bb	Ba(maks)	Bb(maks)	Ha	Ha(maks)	Ka	Kb	E	E1	A	C1	KG
3xSBM-V 90/4	2"	2"	950	350	1085	485	550							188	105
3xSBM-V 90/5							578	810	880	320	430	386	90	216	111
3xSBM-V 90/6							606							244	113

	De	Db	Ba	Bb	Ba(maks)	Bb(maks)	Ha	Ha(maks)	Ka	Kb	E	E1	A	C1	KG
3xSBT-V 90/4	2"	2"	950	345	1065	420	550							184	100
3xSBT-V 90/5							580							206	106
3xSBT-V 90/6							610	820	880	325	395	385	125	228	109
3xSBT-V 90/7							640							250	104
3xSBT-V 90/8							670							272	106
3xSBT-V 90/9							700							294	118

	De	Db	Ba	Bb	Ba(maks)	Bb(maks)	Ha	Ha(maks)	Ka	Kb	E	E1	A	C1	KG
1xSBT-V 100/3	1 1/2"	1 1/2"	275	230	410	415	580							186	44
1xSBT-V 100/4							613							219	45
1xSBT-V 100/5							646	220	175	-	-	100		252	50
1xSBT-V 100/6							679							285	51
1xSBT-V 100/7							712							318	52

	De	Db	Ba	Bb	Ba(maks)	Bb(maks)	Ha	Ha(maks)	Ka	Kb	E	E1	A	C1	KG
2xSBT-V 100/3	2"	2"	695	345	800	500	590							186	96
2xSBT-V 100/4							620							219	99
2xSBT-V 100/5							650	720	645	325	470	465	100	252	110
2xSBT-V 100/6							680							285	111
2xSBT-V 100/7							710							318	112

	De	Db	Ba	Bb	Ba(maks)	Bb(maks)	Ha	Ha(maks)	Ka	Kb	E	E1	A	C1	KG
3xSBT-V 100/3	2 1/2"	2 1/2"	950	345	1065	515	590							186	143
3xSBT-V 100/4							620							219	148
3xSBT-V 100/5							650	820	880	325	480	475	135	252	163
3xSBT-V 100/6							680							285	165
3xSBT-V 100/7							710							318	166

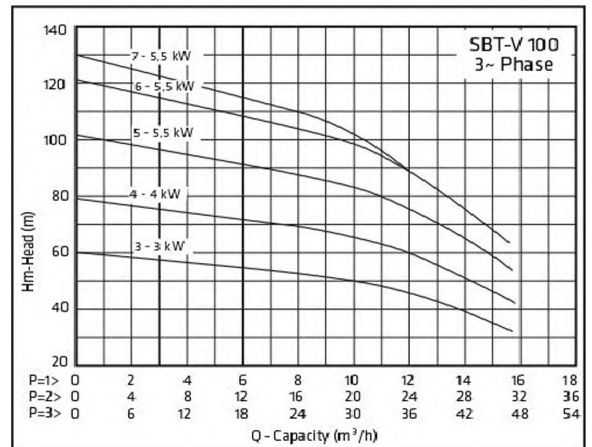
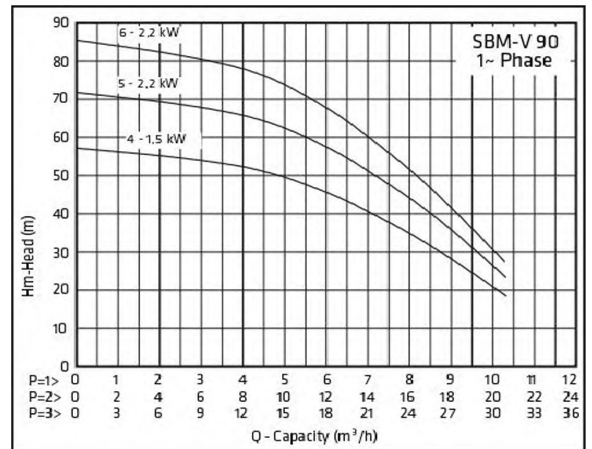
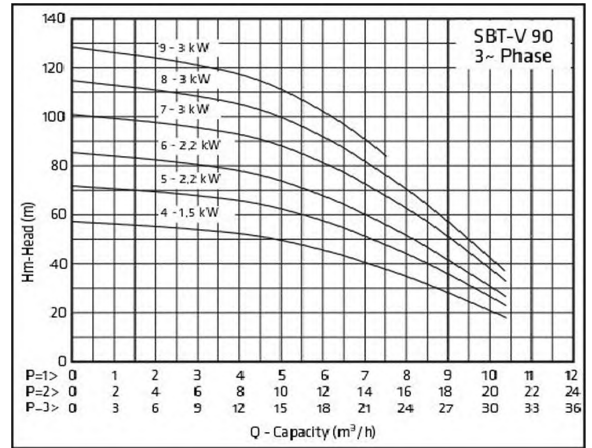

Алматы (7273)495-231
 Ангарск (3955)60-70-56
 Архангельск (8182)63-90-72
 Астрахань (8512)99-46-04
 Барнаул (3852)73-04-60
 Белгород (4722)40-23-64
 Благовещенск (4162)22-76-07
 Брянск (4832)59-03-52
 Владивосток (423)249-28-31
 Владикавказ (8672)28-90-48
 Владимир (4922)49-43-18
 Волгоград (844)278-03-48
 Вологда (8172)26-41-59
 Воронеж (473)204-51-73
 Екатеринбург (343)384-55-89

Иваново (4932)77-34-06
 Ижевск (3412)26-03-58
 Иркутск (395)279-98-46
 Казань (843)206-01-48
 Калининград (4012)72-03-81
 Калуга (4842)92-23-67
 Кемерово (3842)65-04-62
 Киров (8332)68-02-04
 Коломна (4966)23-41-49
 Кострома (4942)77-07-48
 Краснодар (861)203-40-90
 Красноярск (391)204-63-61
 Курск (4712)77-13-04
 Курган (3522)50-90-47
 Липецк (4742)52-20-81

Магнитогорск (3519)55-03-13
 Москва (495)268-04-70
 Мурманск (8152)59-64-93
 Набережные Челны (8552)20-53-41
 Нижний Новгород (831)429-08-12
 Новокузнецк (3843)20-46-81
 Ноябрьск (3496)41-32-12
 Новосибирск (383)227-86-73
 Омск (3812)21-46-40
 Орел (4862)44-53-42
 Оренбург (3532)37-68-04
 Пенза (8412)22-31-16
 Петрозаводск (8142)55-98-37
 Псков (8112)59-10-37
 Пермь (342)205-81-47

Ростов-на-Дону (863)308-18-15
 Рязань (4912)46-61-64
 Самара (846)206-03-16
 Саранск (8342)22-96-24
 Санкт-Петербург (812)309-46-40
 Саратов (845)249-38-78
 Севастополь (8692)22-31-93
 Симферополь (3652)67-13-56
 Смоленск (4812)29-41-54
 Сочи (862)225-72-31
 Ставрополь (8652)20-65-13
 Сургут (3462)77-98-35
 Сыктывкар (8212)25-95-17
 Тамбов (4752)50-40-97
 Тверь (4822)63-31-35

Тольятти (8482)63-91-07
 Томск (3822)98-41-53
 Тула (4872)33-79-87
 Тюмень (3452)66-21-18
 Ульяновск (8422)24-23-59
 Улан-Удэ (3012)59-97-51
 Уфа (347)229-48-12
 Хабаровск (4212)92-98-04
 Чебоксары (8352)28-53-07
 Челябинск (351)202-03-61
 Череповец (8202)49-02-64
 Чита (3022)38-34-83
 Якутск (4112)23-90-97
 Ярославль (4852)69-52-93

Россия +7(495)268-04-70

Казахстан +7(7172)727-132

Киргизия +996(312)96-26-47