



SSP-V

Extra Heavy Duty Slurry Pumps

Алматы (7273)495-231
Ангарск (3955)60-70-56
Архангельск (8182)63-90-72
Астрахань (8512)99-46-04
Барнаул (3852)73-04-60
Белгород (4722)40-23-64
Благовещенск (4162)22-76-07
Брянск (4832)59-03-52
Владивосток (423)249-28-31
Владикавказ (8672)28-90-48
Владимир (4922)49-43-18
Волгоград (844)278-03-48
Вологда (8172)26-41-59
Воронеж (473)204-51-73
Екатеринбург (343)384-55-89

Россия +7(495)268-04-70

Иваново (4932)77-34-06
Ижевск (3412)26-03-58
Иркутск (395)279-98-46
Казань (843)206-01-48
Калининград (4012)72-03-81
Калуга (4842)92-23-67
Кемерово (3842)65-04-62
Киров (8332)68-02-04
Коломна (4966)23-41-49
Кострома (4942)77-07-48
Краснодар (861)203-40-90
Красноярск (391)204-63-61
Курск (4712)77-13-04
Курган (3522)50-90-47
Липецк (4742)52-20-81

Казахстан +7(7172)727-132

Магнитогорск (3519)55-03-13
Москва (495)268-04-70
Мурманск (8152)59-64-93
Набережные Челны (8552)20-53-41
Нижний Новгород (831)429-08-12
Новокузнецк (3843)20-46-81
Ноябрьск (3496)41-32-12
Новосибирск (383)227-86-73
Омск (3812)21-46-40
Орел (4862)44-53-42
Оренбург (3532)37-68-04
Пенза (8412)22-31-16
Петрозаводск (8142)55-98-37
Псков (8112)59-10-37
Пермь (342)205-81-47

Киргизия +996(312)96-26-47

Ростов-на-Дону (863)308-18-15
Рязань (4912)46-61-64
Самара (846)206-03-16
Саранск (8342)22-96-24
Санкт-Петербург (812)309-46-40
Саратов (845)249-38-78
Севастополь (8692)22-31-93
Симферополь (3652)67-13-56
Смоленск (4812)29-41-54
Сочи (862)225-72-31
Ставрополь (8652)20-65-13
Сургут (3462)77-98-35
Сыктывкар (8212)25-95-17
Тамбов (4752)50-40-97
Тверь (4822)63-31-35

Тольятти (8482)63-91-07
Томск (3822)98-41-53
Тула (4872)33-79-87
Тюмень (3452)66-21-18
Ульяновск (8422)24-23-59
Улан-Удэ (3012)59-97-51
Уфа (347)229-48-12
Хабаровск (4212)92-98-04
Чебоксары (8352)28-53-07
Челябинск (351)202-03-61
Череповец (8202)49-02-64
Чита (3022)38-34-83
Якутск (4112)23-90-97
Ярославль (4852)69-52-93

VESTA POMP

Makes life comfortable

SSP-V

Extra Heavy Duty Slurry Pumps

Handled Liquids

Slurry, highly contaminated, viscous, corrosive and abrasive liquids with solid or fibrous particles

Technical Data

Discharge Flange _____ DN 50.....DN 250 mm

Capacity _____ up to 1000 m³/h

Head _____ up to 400 m

Temperature Operation _____ -10°C up to +110 °C

Generating Steam Temperature _____ up to 300°C

Not: The Material of pump differs according to the type of pumped liquid, operating temperature and pressure. Contact for detailed information.

Fields of Application

- Mining and mineral processing
- Sand and gravel processing plants
- Abrasive slurry transfer
- Industrial plants
- Pulp and paper industry
- Cyclone feed
- Mine wastes transfer
- Fly ash and bottom ash transport
- Manure transfer
- Lime mud transport
- Waste water systems
- Chemical slurries

Pump Designation

Pump Type _____

Installation Arrangement Horizontally (H) / Vertically (V) _____

Discharge Nozzle (DN-mm) _____

Pump Suction / Discharge Size (inch) _____

Pump Material Selection _____



Design Features

- SSP-V pump series are carefully designed by taking into consideration years of production experience and field experiences of our customers using process and slurry pumps. Hydraulic efficiency and hardwearing are considerate and optimised while hard solid particles were pumping.
- SSP-V pump series users are offered with advantages of resistant to extensive wear, high reliability, high hydraulic efficiency, cost effective spare parts and continuous spare part supply in short lead time.

Bearing Design

- SSP-V pump series are produced with extra heavy duty (EHD) design. EHD bearings are greased lubricated.

SSP - V 80 3/2 HC

Pump Type _____

Installation Arrangement Horizontally (H) / Vertically (V) _____

Discharge Nozzle (DN-mm) _____

Pump Suction / Discharge Size (inch) _____

Pump Material Selection _____

Features

SSP-V pump series, the bearing group is designed for encountering loads on long column lengths and keeping bearing life much higher than L_{10} nominal bearing life. Corrosive and abrasive properties decrease pump performances in time, distance adjustment between suction side and wear plate on the SSP-V pump series can optimise the pump performances and improve service time. These distance adjustment mechanism does not require any disassemble and distance can be adjusted easily by loosening bolts.

ATTENTION

- HC models in figures have casting volute casing, impeller and wear plates. These parts can be manufactured by rubber and rubber coating.
- Pump and motor connect with belt & pulley. In case of demand, coupling is used for direct connection between motor and pump
- Please get confirmation from our company for dimension of column lengths at pump installation.

Vertical Shaft Extra Heavy Duty Slurry Pumps

SSP-V Field Chart (HC series)

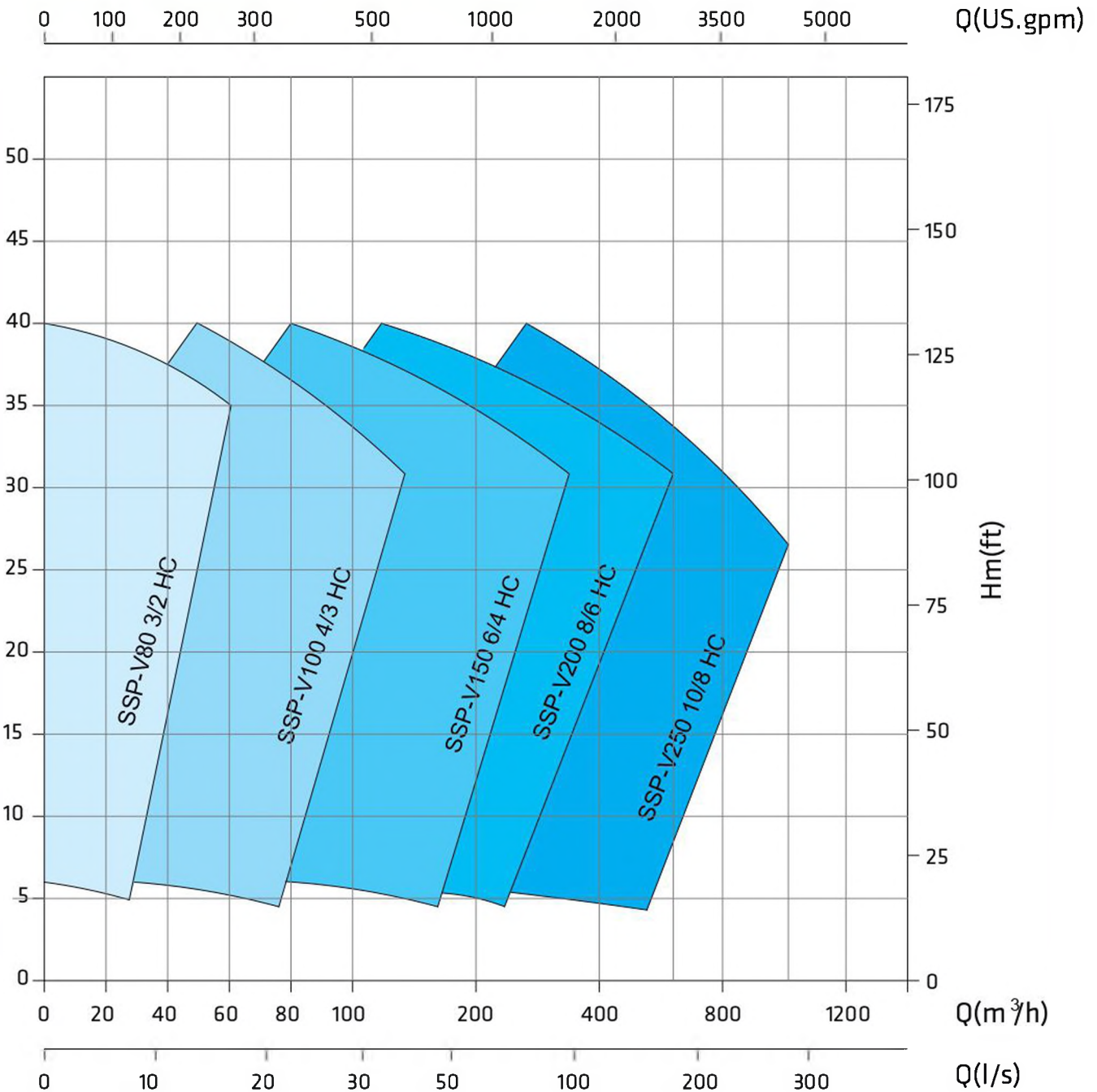

Impeller Types

SSP-V series HC model pumps are centrifugal pumps that have vertical shaft, volute casing, single stage and closed impeller. Semi-open or vortex impeller types can be applied in different requirements. Besides that, mixer feature can be applied on suction side by extending shaft length and helps to avoid clogging by solid particles at suction side

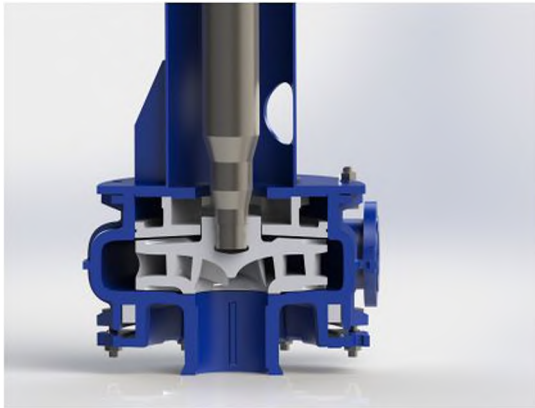

Standard Impeller

Small and medium solid particles are transferred with standard impeller type. On the other hand these impeller types are more efficient than the others. It offers high efficient and more durable solutions regarding material selection and abrasive properties of the handled fluid. It is used for high demanding heads and more efficiency.

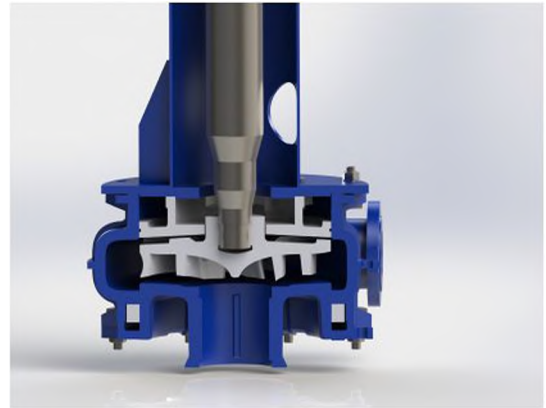

Semi-open Impeller

Large and medium solid particles are transferred with semi-open impeller type. It offers high efficient and more durable solutions regarding material selection and abrasive properties of the handled fluid. Semi-open impellers prevent greater efficient loss in use of larger particles. It is preferred low and medium heads.

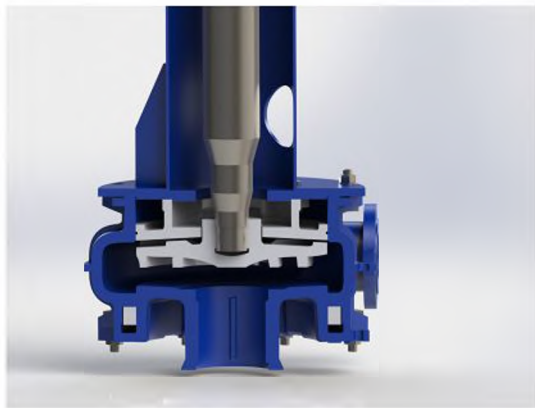

Vortex Impeller

Vortex impellers are used in transfer of fluids containing large solid particles at low head. More life time is offered since large solid particles would have less contact area with the vortex impeller. These impellers are less efficient than the others.

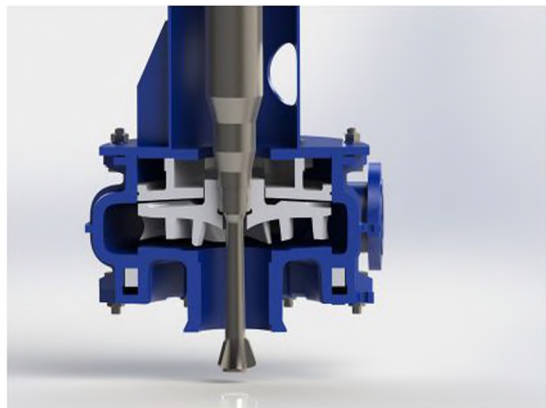

Impeller with Mixer

Add-on mixer provides a homogeneous mixture that has high amount of solid particles at suction side of the pump and prevents over wearing and clogging. Homogeneous fluid that contains high amount of solid particles improves impeller performance due to mixing effect. Mixer in the image is the application on semi-open impeller and same application can be applied on standard and vortex impellers as well.

Recessed Vortex Impeller

Recessed Vortex impellers are applied when large, solid and fibrous particles involved in handled fluid. Minimum contact area is accomplished between solid particles in fluid and the impeller. These impeller types are preferred for preventing damages to solid particles in fluid.

SSP-V Material Options (HC Serisi)

PART LIST	0.6025	0.7040	0.7043	0.7050	1.0619	1.0037	1.4317	1.4525	1.4527	1.4308	1.4412	1.4517	1.4468	1.4469	5.5610	2.1050.01	2.0975.01	2.1096.01	2.0975	1.4021	1.4021(QT)	1.4301	1.4404	1.4460	1.4462	1.0503	
Volute Casing	○	○	○	○	○		○	○	○	○	○	○	○	○	●	○	○	○	○	○							
Impeller	○	○	○	○	○		○	○	○	○	○	○	○	○	●	○	○	○	○	○							
Back Wear Plate	○	○	○	○	○		○	○	○	○	○	○	○	○	●	○	○	○	○	○							
Suction Side	○	○	○	○	○		○	○	○	○	○	○	○	○	●	○	○	○	○	○							
Column Pipe (*)						●																	○	○			
Base Plate						●																	○	○			
Discharge Pipe (*)						●																	○	○			
Cartridge Housing	●	○	○	○																							
Shaft																					●	○	○	○	○	○	○
Bolt, Nut and Washer																							●	○			

(*) Note: Discharge and column pipes can be made of 1.0037 + NBR optionally.

● Standard manufacturing
○ Optional

PART LIST	EPDM	VITON	NBR
O-Ring	●	○	○
Gasket	●	○	○

Material Equivalents

Description	DIN 17007	EN-DIN	AISI / SAE / ASTM
Cast Iron	0.6025	EN-GJL-250 (GG 25)	A48 Class 40B
Nodular Cast Iron	0.7040	EN-GJS-400-15 (GGG 40)	A536 60-40-18
Nodular Cast Iron	0.7043	EN-GJS-400-18-LT (GGG 40.3)	A536 60-40-18
Nodular Cast Iron	0.7050	EN-GJS-500-7 (GGG 50)	A536 88-55-06
Cast Steel	1.0619	GP240GHGS-C25	A216 WCB
Steel	1.0037	St 37-2	A238Gr.C
Martenzitic Stainless Cast Steel	1.4317	G-X 4 CrNi 13 4	A743 CA-6NM
Martenzitic Stainless Cast Steel	1.4525	G-X 5 CrNiCu 16 4	A747 CB7Cu-2
Chrome Nickel Cast Steel (Heat Treated)	1.4308	G-X 6 CrNi 19 10	A743 CF-8
Austenitic Cast Steel (Heat Treated)	1.4412	C-X 5 CrNiMo 19 11 3	A743 CG-3M
Austenitic Cast Steel (Heat Treated)	1.4527	C-X 4 NiCrCuMo 30 20 4	A743 CN-7M
Duplex Steel (Austenitic-Ferritic, Heat Treated)	1.4468	G-X 2 CrNiMoN 25 6 3	A890 3A
Duplex Steel (Austenitic-Ferritic, Heat Treated)	1.4517	G-X 2 CrNiMoN 25 6 3 3	A890 1B
Duplex Steel (Austenitic-Ferritic, Heat Treated)	1.4469	G-X 2 CrNiMo 26 7 4	A890 5A
Wear Resistant Casts	5.5610	EN-GJN-HV600 (XCr23)	A532 Class III Type A
Cast Bronze (Tin Alloy)	2.1050.01	CuSn10	B427 C90700
Cast Bronze (Nickel Alloy)	2.0975.01	CuAl10Ni	B148 C95500
Cast Bronze (Leaded)	2.1096.01	CuSn5ZnPb	B584 C83600
Cast Aluminium Bronze	2.0975	CuAl10 Fe5Ni5	B505 C95800
Carbon Steel	1.0503	C45	AISI 1045
Chrome Steel	1.4021	X20Cr13	A276 Type 420
Chrome Steel (Heat Treated)	1.4021(QT)	X20Cr13	A276 Type 420+QT
Chrome Nickel Steel	1.4301	X5CrNi18-10	A276 Type 304
Chrome Nickel Steel (Low Carbon)	1.4404	X2CrNiMo17-12-2	A276 Type 316
Duplex (Austenitic-Ferritic) Steel	1.4460	X3CrNiMoN27-5-2	AISI 329
Duplex (Austenitic-Ferritic) Steel	1.4462	X2CrNiMoN22-5-3	UNS S32205

Алматы (7273)495-231
Ангарск (3955)60-70-56
Архангельск (8182)63-90-72
Астрахань (8512)99-46-04
Барнаул (3852)73-04-60
Белгород (4722)40-23-64
Благовещенск (4162)22-76-07
Брянск (4832)59-03-52
Владивосток (423)249-28-31
Владикавказ (8672)28-90-48
Владимир (4922)49-43-18
Волгоград (844)278-03-48
Вологда (8172)26-41-59
Воронеж (473)204-51-73
Екатеринбург (343)384-55-89

Иваново (4932)77-34-06
Ижевск (3412)26-03-58
Иркутск (395)279-98-46
Казань (843)206-01-48
Калининград (4012)72-03-81
Калуга (4842)92-23-67
Кемерово (3842)65-04-62
Киров (8332)68-02-04
Коломна (4966)23-41-49
Кострома (4942)77-07-48
Краснодар (861)203-40-90
Красноярск (391)204-63-61
Курск (4712)77-13-04
Курган (3522)50-90-47
Липецк (4742)52-20-81

Магнитогорск (3519)55-03-13
Москва (495)268-04-70
Мурманск (8152)59-64-93
Набережные Челны (8552)20-53-41
Нижний Новгород (831)429-08-12
Новокузнецк (3843)20-46-81
Ноябрьск (3496)41-32-12
Новосибирск (383)227-86-73
Омск (3812)21-46-40
Орел (4862)44-53-42
Оренбург (3532)37-68-04
Пенза (8412)22-31-16
Петрозаводск (8142)55-98-37
Псков (8112)59-10-37
Пермь (342)205-81-47

Ростов-на-Дону (863)308-18-15
Рязань (4912)46-61-64
Самара (846)206-03-16
Саранск (8342)22-96-24
Санкт-Петербург (812)309-46-40
Саратов (845)249-38-78
Севастополь (8692)22-31-93
Симферополь (3652)67-13-56
Смоленск (4812)29-41-54
Сочи (862)225-72-31
Ставрополь (8652)20-65-13
Сургут (3462)77-98-35
Сыктывкар (8212)25-95-17
Тамбов (4752)50-40-97
Тверь (4822)63-31-35

Тольятти (8482)63-91-07
Томск (3822)98-41-53
Тула (4872)33-79-87
Тюмень (3452)66-21-18
Ульяновск (8422)24-23-59
Улан-Удэ (3012)59-97-51
Уфа (347)229-48-12
Хабаровск (4212)92-98-04
Чебоксары (8352)28-53-07
Челябинск (351)202-03-61
Череповец (8202)49-02-64
Чита (3022)38-34-83
Якутск (4112)23-90-97
Ярославль (4852)69-52-93

Россия +7(495)268-04-70

Казахстан +7(7172)727-132

Киргизия +996(312)96-26-47

vpo@nt-rt.ru || <https://vestapomp.nt-rt.ru/>