

## SNV-B

### Vertical Centrifugal Sump Pumps

# INSTRUCTIONS for INSTALLATION , OPERATION & MAINTENANCE

Pump Type	: SNV-B -.....
Pump Serial No	: .....
Head	: .....m3
Capacity	: .....m /h
Motor Power	: .....KW
Speed	: .....RPM

Алматы (7273)495-231  
Ангарск (3955)60-70-56  
Архангельск (8182)63-90-72  
Астрахань (8512)99-46-04  
Барнаул (3852)73-04-60  
Белгород (4722)40-23-64  
Благовещенск (4162)22-76-07  
Брянск (4832)59-03-52  
Владивосток (423)249-28-31  
Владикавказ (8672)28-90-48  
Владимир (4922)49-43-18  
Волгоград (844)278-03-48  
Вологда (8172)26-41-59  
Воронеж (473)204-51-73  
Екатеринбург (343)384-55-89

Иваново (4932)77-34-06  
Ижевск (3412)26-03-58  
Иркутск (395)279-98-46  
Казань (843)206-01-48  
Калининград (4012)72-03-81  
Калуга (4842)92-23-67  
Кемерово (3842)65-04-62  
Киров (8332)68-02-04  
Коломна (4966)23-41-49  
Кострома (4942)77-07-48  
Краснодар (861)203-40-90  
Красноярск (391)204-63-61  
Курск (4712)77-13-04  
Курган (3522)50-90-47  
Липецк (4742)52-20-81

Магнитогорск (3519)55-03-13  
Москва (495)268-04-70  
Мурманск (8152)59-64-93  
Набережные Челны (8552)20-53-41  
Нижегород (831)429-08-12  
Новокузнецк (3843)20-46-81  
Ноябрьск (3496)41-32-12  
Новосибирск (383)227-86-73  
Омск (3812)21-46-40  
Орел (4862)44-53-42  
Оренбург (3532)37-68-04  
Пенза (8412)22-31-16  
Петрозаводск (8142)55-98-37  
Псков (8112)59-10-37  
Пермь (342)205-81-47

Ростов-на-Дону (863)308-18-15  
Рязань (4912)46-61-64  
Самара (846)206-03-16  
Саранск (8342)22-96-24  
Санкт-Петербург (812)309-46-40  
Саратов (845)249-38-78  
Севастополь (8692)22-31-93  
Симферополь (3652)67-13-56  
Смоленск (4812)29-41-54  
Сочи (862)225-72-31  
Ставрополь (8652)20-65-13  
Сургут (3462)77-98-35  
Сыктывкар (8212)25-95-17  
Тамбов (4752)50-40-97  
Тверь (4822)63-31-35

Тольятти (8482)63-91-07  
Томск (3822)98-41-53  
Тула (4872)33-79-87  
Тюмень (3452)66-21-18  
Ульяновск (8422)24-23-59  
Улан-Удэ (3012)59-97-51  
Уфа (347)229-48-12  
Хабаровск (4212)92-98-04  
Чебоксары (8352)28-53-07  
Челябинск (351)202-03-61  
Череповец (8202)49-02-64  
Чита (3022)38-34-83  
Якутск (4112)23-90-97  
Ярославль (4852)69-52-93

Россия +7(495)268-04-70

Казахстан +7(7172)727-132

Киргизия +996(312)96-26-47

<b>Contents</b>	<b>Page</b>
<b>GENERAL INSTRUCTIONS</b>	<b>2</b>
<b>SAFETY INSTRUCTIONS</b>	<b>2</b>
<b>SNV-B PUMPS</b>	<b>3</b>
<b>1. INTRODUCTION</b>	<b>3</b>
<b>2. PUMP CONSTRUCTION</b>	<b>3</b>
<b>3. GENERAL REMARKS</b>	<b>3</b>
<b>4. TEMPORARY STORAGE</b>	<b>3</b>
<b>5. ELECTRICAL CONNECTIONS</b>	<b>3</b>
<b>6. START UP / SHUT DOWN</b>	<b>4</b>
START UP THE PUMP	4
SHUT DOWN THE PUMP	5
<b>7. CHECKS TO BE MADE WHILE THE PUMP IS RUNNING</b>	<b>5</b>
<b>8. LUBRICATION</b>	<b>5</b>
<b>9. DISMANTLING, REPAIRING AND REASSEMBLING THE PUMP</b>	<b>5</b>
DISMANTLING THE PUMP	5
REASSEMBLING THE PUMP	6
<b>10. SPARE PARTS</b>	<b>7</b>
<b>11. FAULTS AND CAUSES</b>	<b>7</b>
<b>12. SECTIONAL DRAWING AND PART LIST</b>	<b>9</b>

## GENERAL INSTRUCTIONS

This manual is intended to be a reference guide for users of pumps providing information on

- Pump installation and maintenance instructions,
- Pumps start-up, operation and shut - down procedures.



– This manual should be kept in a safe place and ALWAYS be available to the QUALIFIED operating and maintenance personnel responsible for the safe operation and maintenance of the pumps.

- Qualified personnel should be experienced and well-informed about safety standards.
- To avoid faulty operation and malfunctioning of pumps, the instructions in this manual are to be CAREFULLY studied and followed at all stages of the pump installation and operating life.
- The user is responsible for ensuring that inspection and installation are carried out by authorized and qualified personnel who have studied this manual carefully.
- The pump should ONLY be used in the operating conditions given on the order for which the pump and materials of the construction have been selected and tested.
- If the pump is to be used for a different application please contact sales office or representative of the manufacturer. refuses to assume any responsibility if the pump is used for different applications without prior written permission.
- If the pump is not installed and operated soon after arrival, it should be stored in a clean and dry place with moderate changes in ambient temperature. Extreme low or high temperatures may severely damage the pump unless suitable precautions are taken. The user is responsible for the verification of the ambient conditions where the pump will be stored or installed.
- does not guarantee repairs or alterations done by user or other unauthorized personnel. The use of original spare parts and accessories authorized by manufacturer will ensure safety.
- This manual does not take into account any site safety regulation, which may apply.

## SAFETY INSTRUCTIONS



***Strictly obey to the following instructions to prevent personal injuries and/or equipment damages:***

- Pump should only be used in the specified operating conditions.
- Any weight, stress or strains on the piping system should not be transmitted to the pump.
- Electrical connections on the motor or accessories must always be carried out by authorized personnel and in accordance to the local codes.
- Any work on the pump should only be carried out when the unit has been brought to standstill.
- Always disconnect the power to the motor and make sure not be switched on accidentally before working on the pump or removing the pump from installation.
- Any work on the pump should be carried out by at least two persons.
- When approaching the pump always be properly dressed and/or wear safety equipment suitable for the work to be done.
- Do not work on the pump when it is hot.
- Do not touch the pump or piping with temperatures higher than 80° C. User must take suitable precaution to warn the persons (e.g. using warning signs, barrier).
- Always be careful when working on pumps handling dangerous liquids (e.g. acids or hazardous fluids).
- Do not work on the pump when the pump and piping connected to the pump are under pressure.
- After completion of the work always fix the safety guards back in places previously removed.
- Do not run the pump in the wrong direction of rotation.
- Do not insert hands or fingers into the pump openings or holes.
- Do not step on the pump and/or piping connected to the pump.

# SNV – B PUMPS

## 1-INTRODUCTION

- SNV-B type pumps are vertical single stage volute casing pumps with suspension column.
- SNV-B type pumps are suitable for clean or slightly contaminated liquids with low viscosity

## 2-PUMP CONSTRUCTION

- The pump is suspended by use of a support plate at the floor level. The discharge pipe is also attached to the support plate. The discharge outlet is above the plate level.
- The pump bearing housing is above the support plate. Pump shaft is supported with grease lubricated rolling bearings.
- Axial thrust is balanced by back wear ring and balance holes in impeller.
- Direction of rotation is clockwise viewed from driver end.

## 3-GENERAL REMARK

- Pump should only be used in the specified operating conditions.
- Never use the pump as anchorage point or carrier for the piping.
- It must be checked that any weight, stress or strains on the piping system should not be transmitted to the pump.
- Prevent impurities such as welding beads, scale sand and tow that might left in the pipes during installation of the piping system which harm the pump.
- When handling liquids at high temperatures thermal expansion of the pipework should be accommodated by suitable means so as to not impose extra load on the pump.
- The foundation should be heavy enough to reduce vibrations and rigid enough to avoid any twisting. The surface of the foundation should be truly horizontal and perfectly flat.

## 4- TEMPORARY STORAGE

- If the pump is not to be installed and operated soon after arrival, store it in a clean and dry place with moderate changes in ambient temperature.
- To prevent the pump from moisture, dust, dirt and foreign materials, suitable steps should be taken.
- The shaft should be revolved periodically to prevent pitting of the bearing surfaces.

## 5- ELECTRICAL CONNECTIONS



- **The electrical engines have to be built in accordance with EN 60034-1.**
- **Enclosures of electrical motors and control systems on the pump unit shall as a minimum give protection in accordance with EN 60529 IP22. But in determining the degree of protection of enclosures of electrical motors and control systems on the pump unit the operating and environmental conditions must be taken into consideration.**
- Electrical connection should be done by a qualified electrician. Current national regulation and motor manufacturer's instructions must be observed.
- Take all safety precautions listed in "Safety instructions." Disconnect all power supplies prior to doing any work.
- The supply cable must be laid in such a way that it never touches the pipework, pump and motor casing.
- Check voltage, phase and frequency on motor nameplate with the mains.
- The electric motor must be protected against overloading by means of circuit breakers and/or fuses. Circuit breakers and fuses must be selected in accordance with full load amperage of the motor appearing on the motor rating plate.
- It is recommended to use PTC (passive thermal control) on motor, but this is optional depending on customer requirement. In case of using PTC, these should be connected via corresponding terminals in the terminal box and the PTC should be connected to the thermal trip mechanism.
- Prior to connecting the electrical wiring rotate the pump shaft by hand to make sure rotor rotates easily.
- Connect the electrical wiring in accordance with local electrical codes and make sure to ground the motor.

- The connection diagram can be found in the terminal box of the motor or in the instruction manual.
- The mains connection on the tagboard depends on the nominal power of the motor, the power supply and the type of connection. The necessary connection of the bridges in the terminal box is shown in the following (Table 1. and Fig. a, b, c).

Table 1

Type of switch	Power of motor $P_N \leq 4 \text{ kW}$	Power of motor $P_N > 4 \text{ kW}$
	power supply 3 ~ 400 V	power supply 3 ~ 400 V
direct	Y – connection (b)	$\Delta$ – connection (a)
Y / $\Delta$ - start	Impossible	Remove connecting bridges (c)

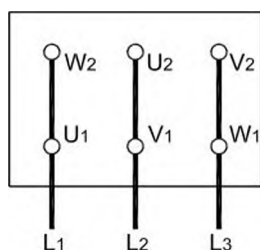

Fig. a.  $\Delta$  - connection

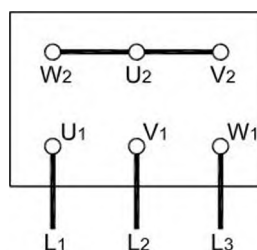

Fig. b. Y – connection

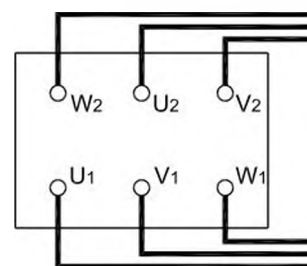

Fig. c. Y /  $\Delta$  - Start

## 6- START UP/SHUT DOWN

### Preparations:

- **Lubrication Control:** The bearings of SNV-B type pumps are normally life-time grease lubricated, and they are maintenance free. Depending on customer requirement pump with regreaseable bearings are available. In this case, grease lubricated bearings are factory packed with grease enough for one year operation before dispatch. Before initial start-up the pump, it should be ascertained that no dirt has penetrated inside the bearings during transport or installation on site. Otherwise, the bearings should be cleaned out and repacked with fresh grease before start up.
- The free level of the liquid in the suction tank always must be above the volute casing. **Make sure the pump never runs dry.**
- **Checking the direction of rotation:** The direction of rotation must match the arrow on the pump. Check this by switching the pump on, then off again immediately. **Fit the coupling guards back in place if you took it out.**

### START UP THE PUMP

- Check if the shut-off valve in the discharge line is closed.
- Switch on the circuit breaker and run the motor.
- Wait until the motor reaches the full speed (on star-delta running motors wait until it switches on delta).
- Open the discharge valve slowly while watching the amperemeter on the control panel (If the discharge line is empty do not turn on the valve fully open on the first start up. Turn it slowly to maintain the valve on the amperemeter is under the rated current value of the motor).
- When the valve is fully open, check the pressure on the manometer and see it is the same with the duty point pressure. If the pressure on the manometer is lower than duty point pressure bring it to the duty point value by slightly closing the valve. If it is higher value, check your installation, particularly head again.

ATTENTION: The pump should be shut down at once and the trouble should be corrected if the pump is running at its rated speed and found any of the following faults:

- Pump does not deliver any water,
- Pump does not deliver enough water,
- Flow is going down,

- Discharge pressure is not enough,
- Driver overloaded,
- Vibration on pump,
- High noise level,
- Bearing overheating.

### **SHUT DOWN THE PUMP**

- Slowly close the shut-off valve in the discharge line (You may shut down the pump without closing the shut-off valve if there is a device for water hammer protection on the discharge line or the water hammer is not at a considerable level).
- Switch off the driver. Ensure the pump set runs down smoothly and quietly to a standstill.

### **7- CHECKS TO BE MADE WHILE THE PUMP IS RUNNING**

- The pump must run smoothly, quietly and free from vibration at all times.
- The pump must never run dry.
- Never run the pump for a long period against a closed discharge valve (at zero flow).
- The bearing temperature may exceed the ambient temperature by up to 50 °C .But must never rise above 80 °C.
- The flexible coupling elements should be regularly checked and replaced as soon as they are shown signs of wear.
- Occasionally check the motor current. Stop the motor if the amperage is higher than usual; there may be jamming or friction in the pump. Make the necessary mechanical and electrical checks.
- Stand-by pumps should be run for a short time at least once a week to ensure they are in constant readiness for operation.

### **8- LUBRICATION**

- The bearings of SNV-B type pumps are normally life–time grease lubricated, and they are maintenance free.
- Depending on customer requirement pump with regreaseable bearings are available. In this case,grease lubricated bearings are factory packed with grease enough for one year operation before dispatch.
- The grease should be changed after 3000 hours or two year at the longest of operation.
- Use high quality lithium soap grease.

### **9- DISMANTLING, REPAIRING AND REASSEMBLING THE PUMP**

**WARNING:** Before starting work on the pump set, make sure it is disconnected from the mains and can not be switched on accidentally.

#### **DISMANTLING THE PUMP**

- Close the discharge valve.
- Disconnect the motor (600) from the motor pedestal (011).
- Disconnect discharge pipe (240) from the piping system.
- Unscrew the anchor bolts of pump support plate (801).
- Take the pump out of the pit and place the pump on the ground carefully in horizontal position.
- Unscrew the pump discharge flange (245) by turning in counter clockwise direction.
- Disconnect the flange (281) for fixing the discharge pipe and take out the rubber gasket (283).
- Disconnect the discharge pipe (240) from the volute casing (001).
- Disconnect the volute casing from the column pipe (101).
- Unscrew the shaft locking nut (65) and remove in sequence impeller (50), shaft key (210), sliding bearing housing (003).
- Disconnect the cover of sliding bearing (037)from the sliding bearing housing (003) and remove the sliding bearing bush (036).
- Disconnect the column pipe (101) from the main rolling bearings housing (031).
- Disconnect the pump support plate (801) from the main rolling bearings housing (031).
- Disconnect the motor pedestal (011) from the main bearing housing (031).
- Unscrew shaft locking nut and washer (392).
- Disconnect the coupling half (085)from the shaft (060) using a pull-off device and remove key (212).
- Disconnect the cover of the upper rolling bearing housing (035) and remove the spacer sleeve (075).
- Disconnect the cover of the main rolling bearings housing (034).
- Disconnect the main bearing housing (031) from the upper bearing housing (030).
- Remove the outer ring of NU bearing (202) by using a suitable device.

- Remove the upper bearing housing (030) using a suitable way.
- Disconnect in sequence upper bearing (201) and inner ring of NU bearing (202) from the shaft (060)

### **REASSEMBLING THE PUMP**

Reassemble in accordance with standard engineering practice. Clean all the parts replace damaged or worn-out ones.

- Fit the outer ring of the NU type bearing (202) to the main bearing housing (031).
- Mount the upper bearing housing (030) to the main bearing housing (031).
- Mount the inner ring of the NU type bearing (202) onto the shaft (060) and fit the retaining ring (220).
- Mount the upper ball bearing (201) onto the shaft (060).
- Mount the shaft (060) to the bearing housing (30 and 031).
- Slip the spacer sleeve (075) onto the shaft (060).
- Fit the grease seal (410) to the cover of the upper rolling bearing housing (035).
- Mount the cover (035) to the upper bearing housing (030).
- Fit the key (212) onto the shaft (060).
- Mount the coupling half (085) onto the shaft (060) with the aid of a pusher device.
- Screw the shaft locking nut and washer (392) on to the shaft (060).
- Fit the grease seal (411) to the cover of the main rolling bearing housing (34).
- Mount the cover (034) to the main rolling bearing housing (031).
- Mount the support plate (801) onto the main rolling bearing housing (031).
- Mount the column pipe (101) to the main rolling bearing housing (031).
- Insert the sliding bearing bush (036) into the sliding bearing housing (003).
- Mount the cover of sliding bearing (037) to the sliding bearing housing (003).
- Fit the sliding bearing housing (003) onto the column pipe(101).
- Fit the impeller key (210) and mount the impeller (050) onto the shaft (060).
- Screw the impeller nut (065).
- Mount the volute casing (001) to the column pipe (101).
- Slip the lower part of the fixing flange (282) onto the discharge pipe (240).
- Mount the discharge pipe (240) to the volute casing (001).
- Slip the rubber gasket (283) and upper part of the fixing flange (281) onto the discharge pipe (240).
- Connect the upper and lower parts of the fixing flanges (281 and 282).
- Screw the pump discharge flange (245) onto the discharge pipe (240) by turning in clockwise direction.
- Mount the motor pedestal (011) to the main bearing housing (031).
- Fit the coupling rubber (086) onto the coupling half (085).
- Mount the other coupling half (087) onto the motor shaft (600).
- Mount the motor (600) to the pump.

**ATTENTION:** Do not forget to place the o-rings shown on the sectional drawing (420-421).

## 10- SPARE PARTS

- guarantees to supply the spare parts for SNV-B type pumps for 10 year. You can provide any spare parts easily.
- Let us know the following details written on the name-plate when you order spare parts:

Pump Type and Size : SNV-B 125-315  
 Motor Power and Speed : 30 kW-1450 rpm  
 Prod. Year and Serial Number : 1998-14250  
 Capacity and Head : 200 m<sup>3</sup>/h–30m

- If you prefer to have spare parts in your stock, we recommend you to have following quantities for two years operation depending on the number of the same type of pumps (*Table 2*).

(*Table 2*).

Part No	Part Name	Number of pumps in the system						
		2	3	4	5	6-7	8-9	10+
60	Shaft (with keys and nuts)	1	1	2	2	2	3	30%
50	Impeller	1	1	1	2	2	3	30%
20 - 21	Wear Rings (if any)	4	4	4	6	6	8	50%
201	Rolling Bearing (set)	2	2	4	4	6	8	50%
202	Sliding Bearing Bush	4	4	4	6	6	8	50%
420 - 421	O-Ring (set)	4	6	8	8	9	12	150%

## 11- FAULTS AND CAUSES

In this section you will find faults at operations and their reasons for SNV-B pumps.

### 1 – Pump doesn't deliver any water after start-up.

- a. There may be air existing in pump.
- b. Insufficient manometric head.
- c. Reverse rotation.
- d. Speed too low.
- e. Impeller or check – valve is clogged.

### 2 – Flow is going down or no flow at all.

- a. Water free surface in the suction pit is too low. Pump lifts the water with air.
- b. Increase at total manometric head.
- c. Impeller or strainer is clogged partially.

### 3 – Driver overloaded.

- a. Pump is operating at lower manometric head.
- b. Speed is too high.
- c. Mechanical frictions inside the pump.

### 4 – Bearings overheating.

- a. Insufficient lubrication, deterioration of grease or no grease.
- b. Bearing covers are too tight.
- c. Insufficient cooling.
- d. Existence of excess grease.



**5 – Vibration on pump.**

- a. Unbalanced rotating parts.
- b. Partially clogged impeller.
- c. Worn – out and defected impeller.
- d. Oblique shaft.

**6 – Noise level is high.**

- a. Flow rate is too high or too low. Pump runs out of duty range.
- b. There is air in water.
- c. Pump is working at cavitation conditions.

## 12 - SECTIONAL DRAWING AND PART LIST

### Part List

001	Volute casing	420	O – ring
003	Sliding bearing housing	421	O – ring
011	Motor Pedestal	600	Electric motor
*020	Wear ring (Volute casing)	801	Support plate
*021	Wear ring (Sliding bearing housing)		
030	Upper bearing housing		
031	Main bearing housing		
034	Cover (Main bearing housing)		
035	Cover (Upper bearing housing)		
036	Sliding bearing bush		
037	Cover (Sliding bearing)		
050	Impeller		
060	Shaft		
065	Impeller nut		
075	Spacer sleeve		
085	Coupling half (Pump)		
086	Coupling rubber		
087	Coupling half (Motor)		
101	Column pipe		
201	Upper ball bearing (With lower side closed)		
202	Cylindrical roller bearing		
210	Impeller key		
212	Coupling key		
220	Retaining ring		
240	Discharge pipe		
245	Discharge flange		
260	Grease nipple		
281	Fixing flange (upper)		
282	Fixing flange (lower)		
283	Rubber gasket		
392	Shaft locking nut + Washer		
410	Grease seal (Upper)		
411	Grease seal (Lower)		

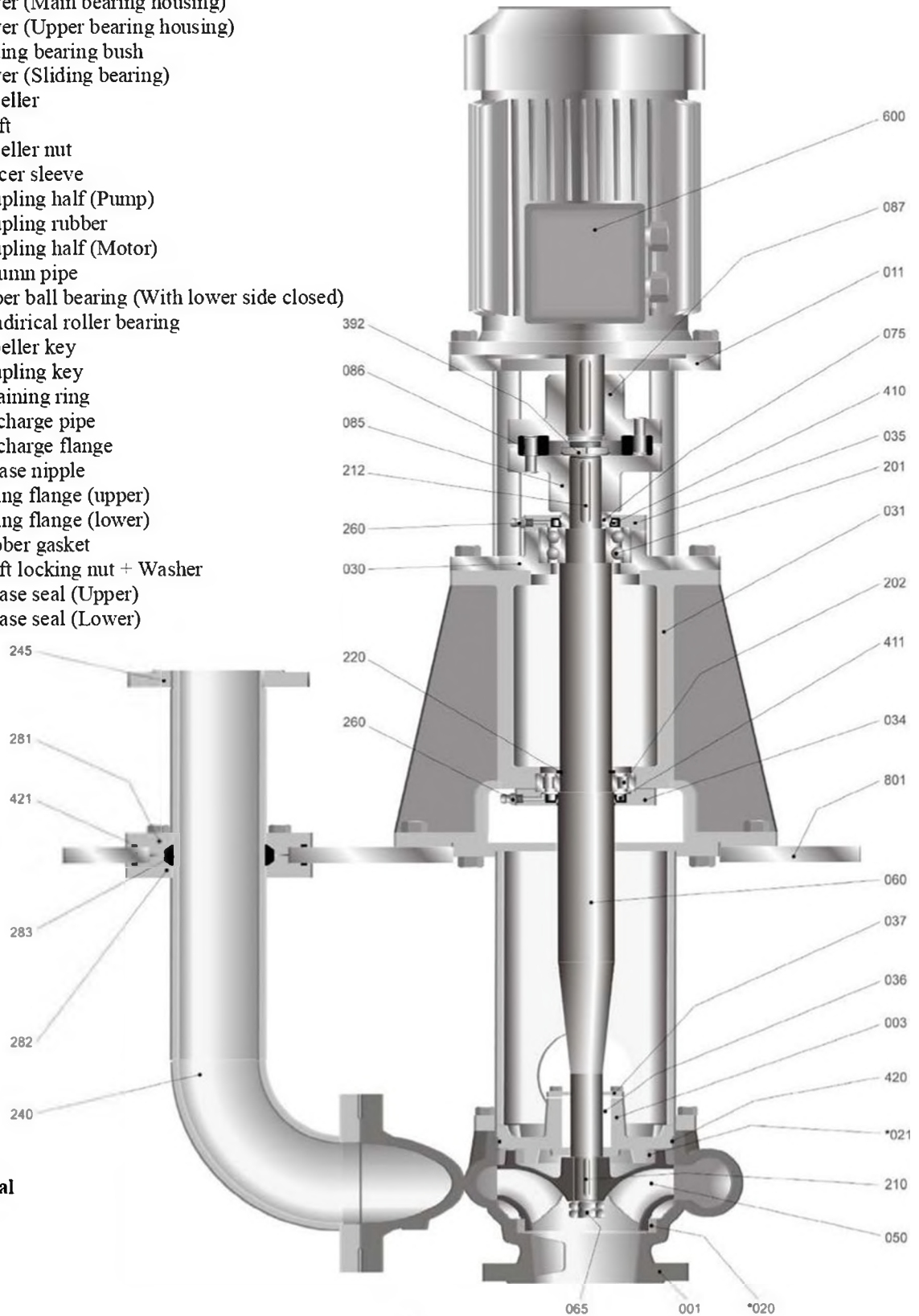

( \* ) Optional

Алматы (7273)495-231  
Ангарск (3955)60-70-56  
Архангельск (8182)63-90-72  
Астрахань (8512)99-46-04  
Барнаул (3852)73-04-60  
Белгород (4722)40-23-64  
Благовещенск (4162)22-76-07  
Брянск (4832)59-03-52  
Владивосток (423)249-28-31  
Владикавказ (8672)28-90-48  
Владимир (4922)49-43-18  
Волгоград (844)278-03-48  
Вологда (8172)26-41-59  
Воронеж (473)204-51-73  
Екатеринбург (343)384-55-89

Россия +7(495)268-04-70

Иваново (4932)77-34-06  
Ижевск (3412)26-03-58  
Иркутск (395)279-98-46  
Казань (843)206-01-48  
Калининград (4012)72-03-81  
Калуга (4842)92-23-67  
Кемерово (3842)65-04-62  
Киров (8332)68-02-04  
Коломна (4966)23-41-49  
Кострома (4942)77-07-48  
Краснодар (861)203-40-90  
Красноярск (391)204-63-61  
Курск (4712)77-13-04  
Курган (3522)50-90-47  
Липецк (4742)52-20-81

Казахстан +7(7172)727-132

Магнитогорск (3519)55-03-13  
Москва (495)268-04-70  
Мурманск (8152)59-64-93  
Набережные Челны (8552)20-53-41  
Нижний Новгород (831)429-08-12  
Новокузнецк (3843)20-46-81  
Ноябрьск (3496)41-32-12  
Новосибирск (383)227-86-73  
Омск (3812)21-46-40  
Орел (4862)44-53-42  
Оренбург (3532)37-68-04  
Пенза (8412)22-31-16  
Петрозаводск (8142)55-98-37  
Псков (8112)59-10-37  
Пермь (342)205-81-47

Киргизия +996(312)96-26-47

Ростов-на-Дону (863)308-18-15  
Рязань (4912)46-61-64  
Самара (846)206-03-16  
Саранск (8342)22-96-24  
Санкт-Петербург (812)309-46-40  
Саратов (845)249-38-78  
Севастополь (8692)22-31-93  
Симферополь (3652)67-13-56  
Смоленск (4812)29-41-54  
Сочи (862)225-72-31  
Ставрополь (8652)20-65-13  
Сургут (3462)77-98-35  
Сыктывкар (8212)25-95-17  
Тамбов (4752)50-40-97  
Тверь (4822)63-31-35

Тольятти (8482)63-91-07  
Томск (3822)98-41-53  
Тула (4872)33-79-87  
Тюмень (3452)66-21-18  
Ульяновск (8422)24-23-59  
Улан-Удэ (3012)59-97-51  
Уфа (347)229-48-12  
Хабаровск (4212)92-98-04  
Чебоксары (8352)28-53-07  
Челябинск (351)202-03-61  
Череповец (8202)49-02-64  
Чита (3022)38-34-83  
Якутск (4112)23-90-97  
Ярославль (4852)69-52-93

vpo@nt-rt.ru || <https://vestapomp.nt-rt.ru/>