

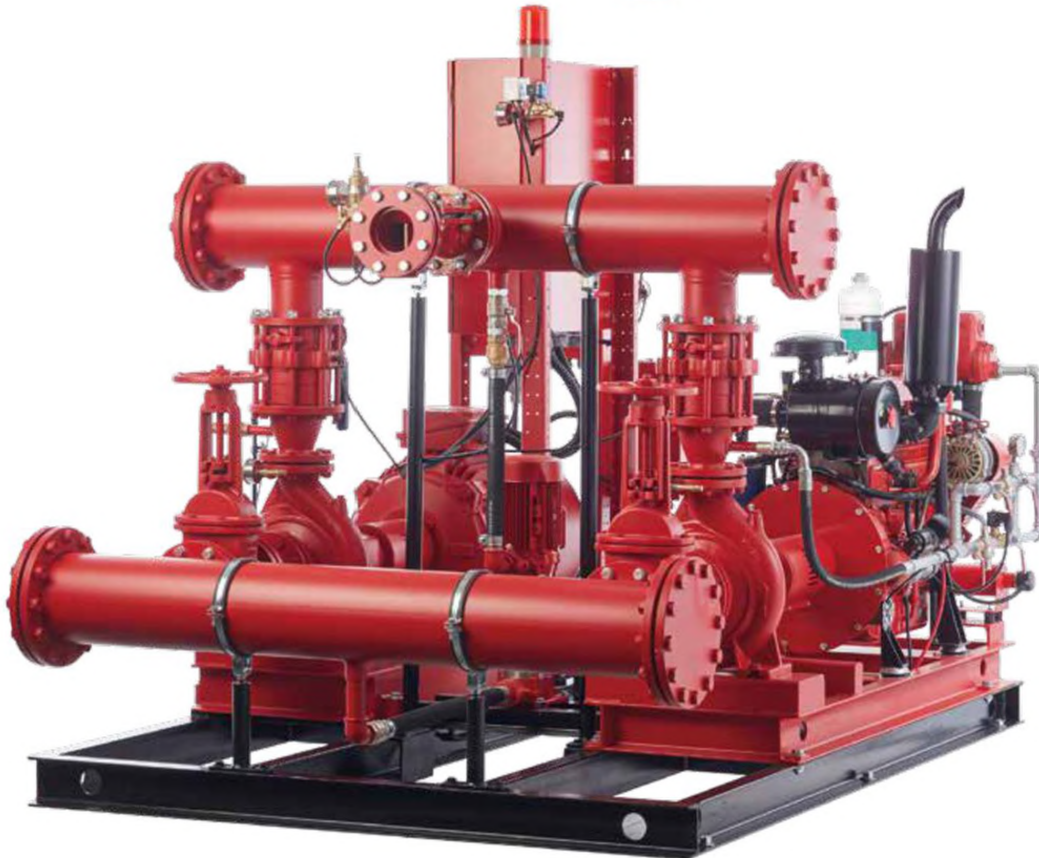

FIRE PUMPS



Алматы (7273)495-231
 Ангарск (3955)60-70-56
 Архангельск (8182)63-90-72
 Астрахань (8512)99-46-04
 Барнаул (3852)73-04-60
 Белгород (4722)40-23-64
 Благовещенск (4162)22-76-07
 Брянск (4832)59-03-52
 Владивосток (423)249-28-31
 Владикавказ (8672)28-90-48
 Владимир (4922)49-43-18
 Волгоград (844)278-03-48
 Вологда (8172)26-41-59
 Воронеж (473)204-51-73
 Екатеринбург (343)384-55-89

Россия +7(495)268-04-70

Иваново (4932)77-34-06
 Ижевск (3412)26-03-58
 Иркутск (395)279-98-46
 Казань (843)206-01-48
 Калининград (4012)72-03-81
 Калуга (4842)92-23-67
 Кемерово (3842)65-04-62
 Киров (8332)68-02-04
 Коломна (4966)23-41-49
 Кострома (4942)77-07-48
 Краснодар (861)203-40-90
 Красноярск (391)204-63-61
 Курск (4712)77-13-04
 Курган (3522)50-90-47
 Липецк (4742)52-20-81

Казахстан +7(7172)727-132

Магнитогорск (3519)55-03-13
 Москва (495)268-04-70
 Мурманск (8152)59-64-93
 Набережные Челны (8552)20-53-41
 Нижний Новгород (831)429-08-12
 Новокузнецк (3843)20-46-81
 Ноябрьск (3496)41-32-12
 Новосибирск (383)227-86-73
 Омск (3812)21-46-40
 Орел (4862)44-53-42
 Оренбург (3532)37-68-04
 Пенза (8412)22-31-16
 Петрозаводск (8142)55-98-37
 Псков (8112)59-10-37
 Пермь (342)205-81-47

Киргизия +996(312)96-26-47

Ростов-на-Дону (863)308-18-15
 Рязань (4912)46-61-64
 Самара (846)206-03-16
 Саранск (8342)22-96-24
 Санкт-Петербург (812)309-46-40
 Саратов (845)249-38-78
 Севастополь (8692)22-31-93
 Симферополь (3652)67-13-56
 Смоленск (4812)29-41-54
 Сочи (862)225-72-31
 Ставрополь (8652)20-65-13
 Сургут (3462)77-98-35
 Сыктывкар (8212)25-95-17
 Тамбов (4752)50-40-97
 Тверь (4822)63-31-35

Тольятти (8482)63-91-07
 Томск (3822)98-41-53
 Тула (4872)33-79-87
 Тюмень (3452)66-21-18
 Ульяновск (8422)24-23-59
 Улан-Удэ (3012)59-97-51
 Уфа (347)229-48-12
 Хабаровск (4212)92-98-04
 Чебоксары (8352)28-53-07
 Челябинск (351)202-03-61
 Череповец (8202)49-02-64
 Чита (3022)38-34-83
 Якутия (4112)23-90-97
 Ярославль (4852)69-52-93

FIRE PUMPS CONFORM TO NFPA 20



NFPA 20 standard defines the installation requirements of the fixed pumps for fire protection. This standard is the most common and the most detailed standard in the world used for fire protection services.

The scope of NFPA 20 document include the selection of fire pumps, installation, acceptance tests and operation.

Standart Pompa, being a member of NFPA, follows all studies and publications related within the fire protection area.

Most of the consultant companies related with fire protection system design are making their designs according to NFPA standards. Besides, insurance companies are not taking risk and reducing the policy costs, if the fire system is not designed according to NFPA standards and the fire pumps are not selected according to NFPA 20.

Fire Fighting Pump Features

fire pumps are used to pressurize and keep the pressure of fire fighting systems such as;

- Sprinkler
- Fire Cabinets
- Hydrants

Different type of pumps may be used in fire fighting systems;

- End suction pumps
- Vertical in-line pumps
- Double suction split-case pumps
- Multistage pumps

Fire pumps an groups fully conform the requirements of NFPA 20

- Seperate controller for each pump.
- Max. flow velocity in suction pipe is below 3 m/s at rated capacity
- Pressure at zero flow is less than 1.4 times rated pressure
- Pressure at 1.5 x rated capacity is not less than 0.65 x rated pressure
- Service factor shall not exceed 1.15
- Materials;

Casing	: Cast iron
Impeller	: Bronze
Shaft	: Stainless steel
- Shaft sealing: Soft packing or mechanical seal
- Bearings: L-10 rating of not less than 5000 hours at maximum load.
- Flanges according to EN 1092-2 PN 16.

Suggested accesories on the pump

- Automatic air release valve
- Circulation relief valve
- Increaser and reducer piping elements
- Pressure gauges at suction and discharge
- Flexible coupling

Fire Pump Performance Characteristics Conform to NFPA 20

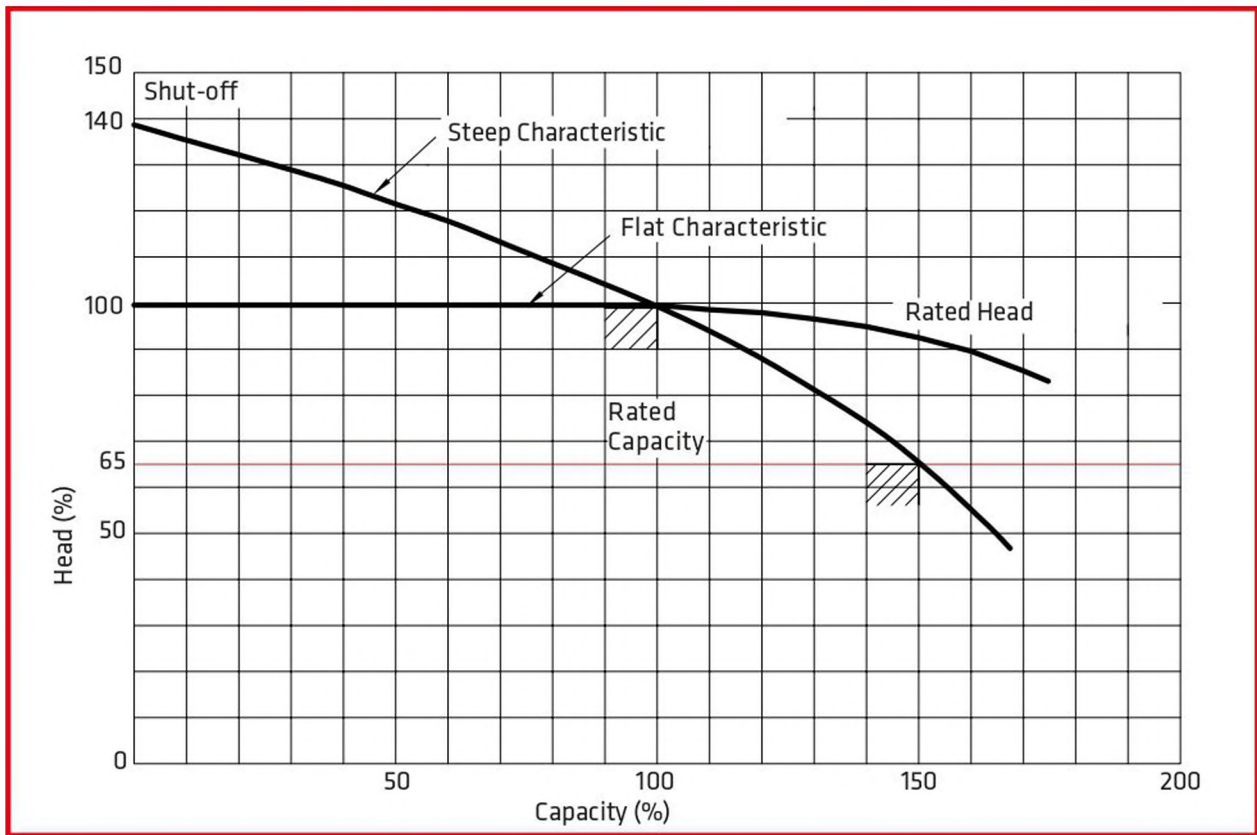

Fire Pump Capacities Conform to NFPA 20

Rated capacities as per NFPA 20 [2016]

(GPM)	(l/min)	(m ³ /h)
25	95	5,7
50	189	11,4
100	379	22,7
150	568	34,1
200	757	45,4
250	946	56,8
300	1136	68,1
400	1514	91
450	1703	102
500	1892	114
750	2893	170
1000	3785	227
1250	4731	284
1500	5677	341
2000	7570	454
2500	9462	568
3000	11355	681
3500	13247	795
4000	15140	908
4500	17032	1022
5000	18925	1136

Fire Pump Types

SNT End Suction



Horizontal, radially split volute casing type , single stage, end suction centrifugal pump with closed impeller.

rated capacities (GPM)			rated pressures (m)
25	400	2000	40
50	450	2500	50
100	500	3000	60
150	750	3500	70
200	1000	4000	80
250	1250	4500	90
300	1500	5000	100

SDS Double Suction



Horizontal, single stage, axially split volute casing pumps with double suction radial impellers.

rated capacities (GPM)		rated pressures (m)
400	2000	50
450	2500	60
500	3000	70
750	3500	80
1000	4000	90
1250	4500	100
1500	5000	110
		120
		140

SKM Multistage

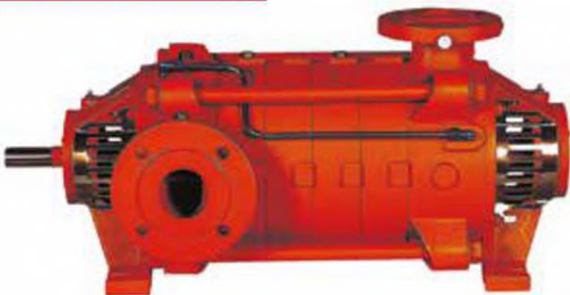

Horizontal ring section multistage centrifugal pumps with closed impellers and diffusers.

rated capacities (GPM)			rated pressures (m)	
25	300	1000	60	120
50	400	1250	70	130
100	450	1500	80	140
150	500	2000	90	150
200	750	2500	100	160
250			110	170

SKM Multistage - Multioutlet



Multioutlet design horizontal ring section multistage centrifugal pumps with closed impellers and diffusers.

rated capacities (GPM)			rated pressures (m)	
25	300	1000	60	120
50	400	1250	70	130
100	450	1500	80	140
150	500	2000	90	150
200	750	2500	100	160
250			110	170

Fire Pump with Electric Motor

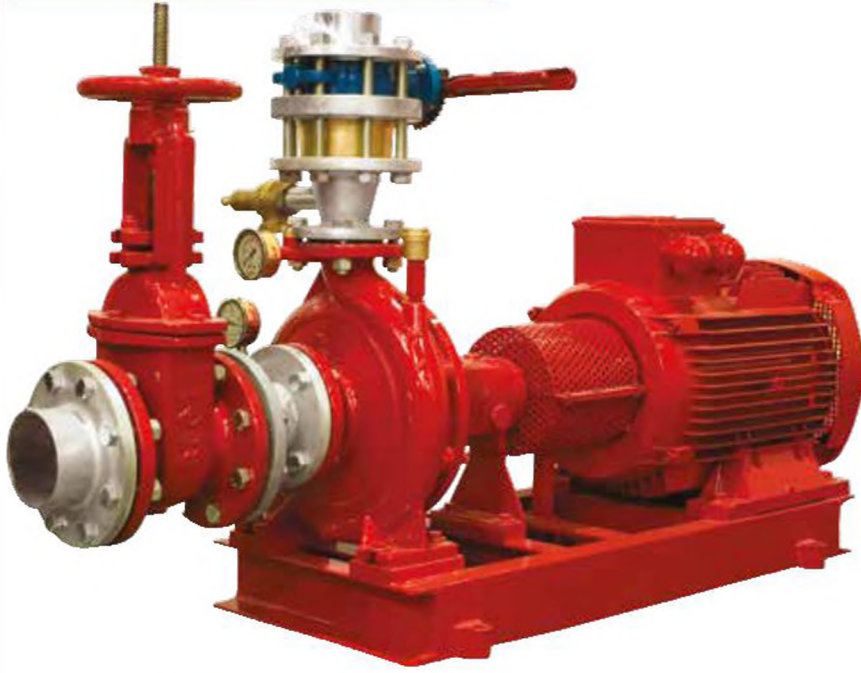

Fire Pump with Diesel Engine

Generally 100 % redundancy is obtained by diesel engine-driven pumps. The requirements of diesel engine-driven pumps are defined in NFPA 20.

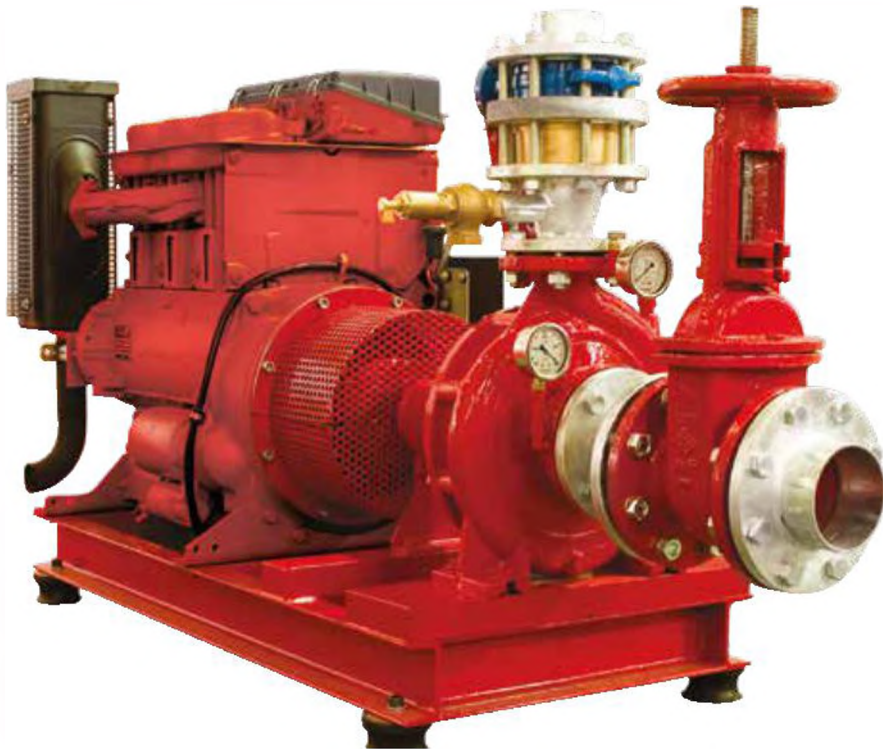

Jockey Pump

Jockey pumps should be selected at a capacity at which to increase the system pressure to the required value in 10 minutes after sensing the leakage in fire fighting system.

Generally a pump with % 3 of rated capacity (min 1 GPM), % 110 of rated pressure.



Fire Pump Group Operation Algorithm

Manual Electric Control

The manually operated switch (push button) can be used to run the motor manually. In this case operation can not be affected by the pressure-actuated switch.

Mechanical Control

Emergency run handle on the controller can be used to operate pumps by mechanically closing the motor-circuit switching mechanism.

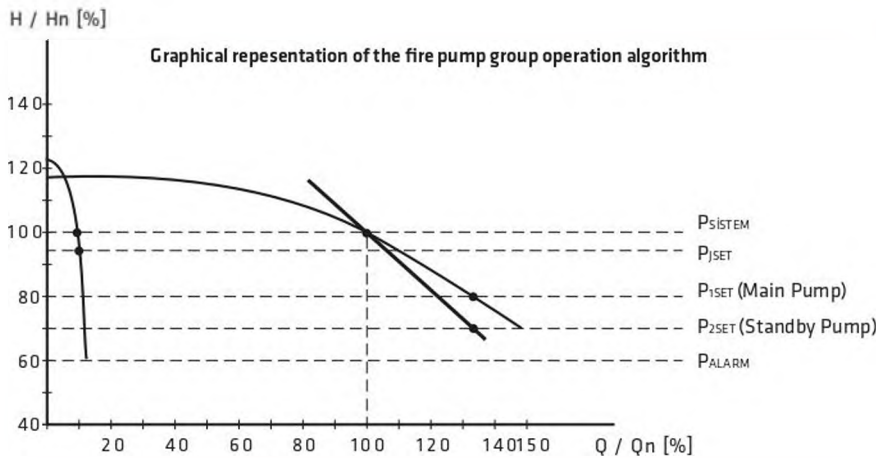

If the pressure drops below the set value (P_{JSET}), jockey pump starts running with the signal coming from the pressure switch and continues to run for 10 minutes until the system pressure reaches the set value (P_{SYSTEM}). If the pressure continues to drop, (P_{ISET}) first the main pump starts to run. If the system pressure (P_{SYSTEM}) can not supplied and pressure continues the drop

P&I Diagram for Fire Fighting Groups Conform to NFPA20

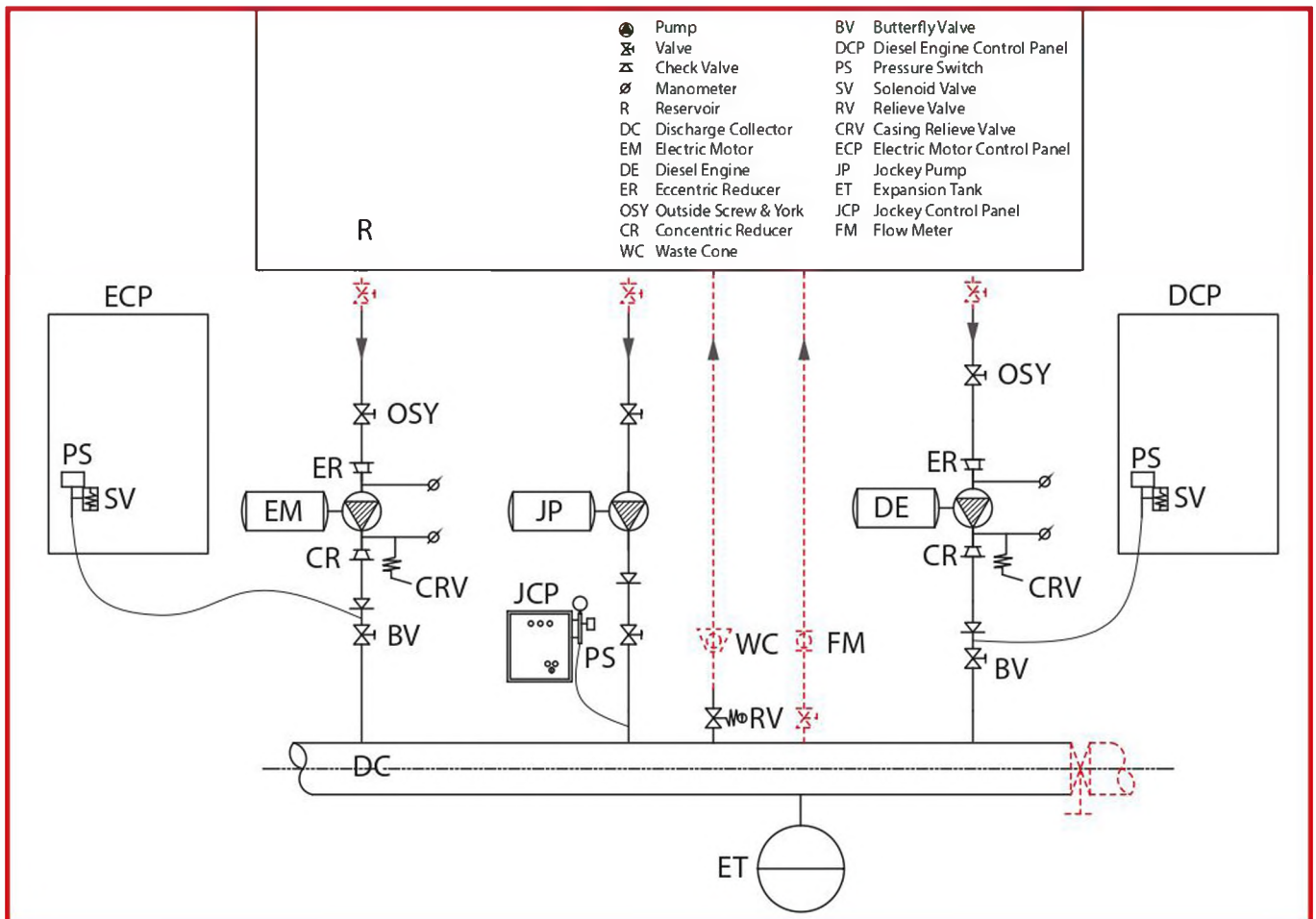

Automatic Operation Algorithm In Case Of Fire

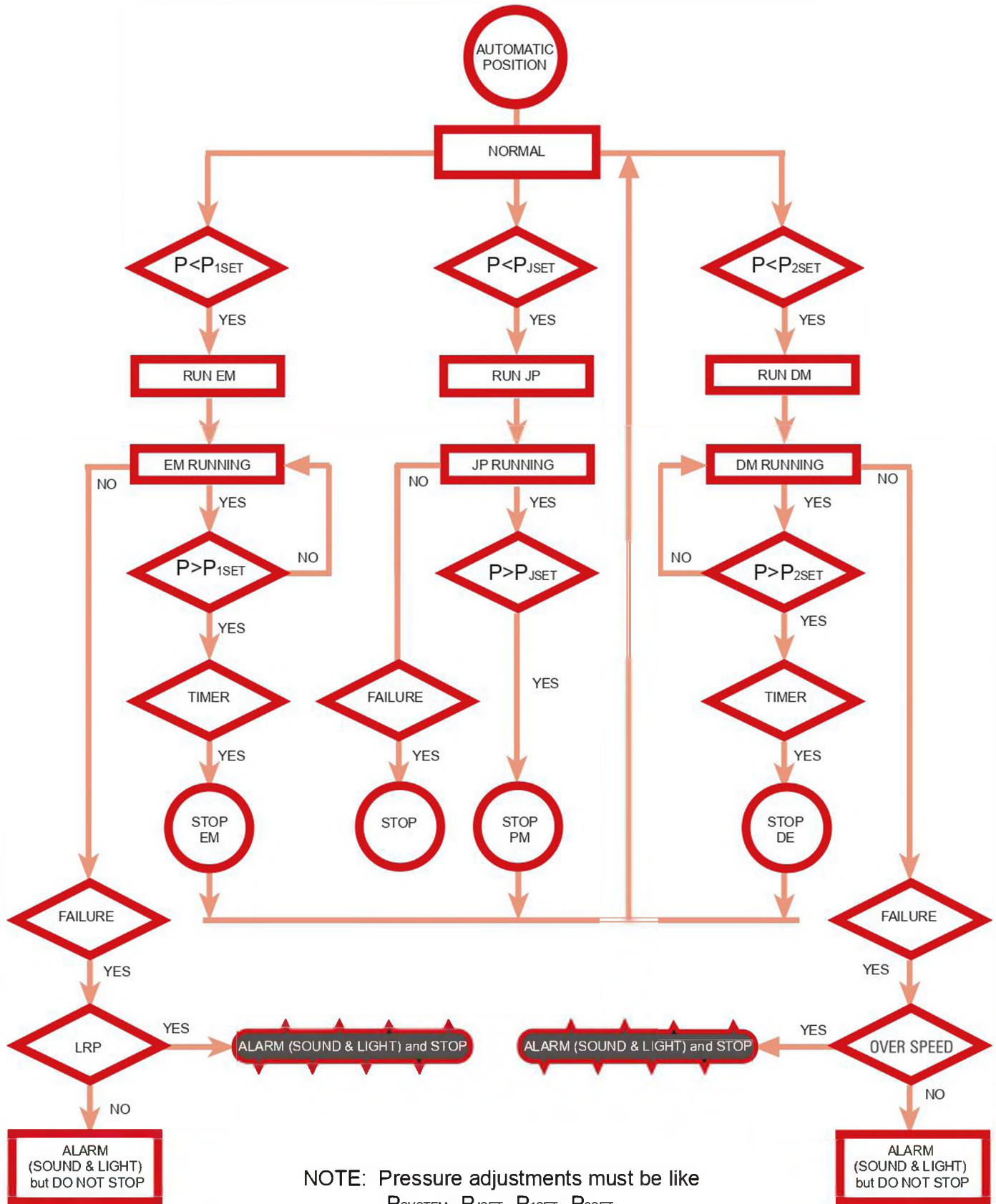

Control Panel

Control Panels According to NFPA 20

For Electric Motor



For Diesel Engine



The pictures used are representative.

Fire Pump Group Control System

- Individual control panels are used for electric pump, diesel pump and jockey pump
- Lock mechanism are used on panels
- Continuous grounding
- Pumps can run by manual control and emergency-run mechanical control on controller
- By the help of Locked Rotor Protection (LRP), in case of locking rotor main switch is automatically shut down.
- No thermic protection on controller (except jockey pump controller)
- Alarm signals on electric pump controller (except jockey pump)

1. pump running
2. pump failure
3. minimum water level(if required)
4. phase reversal
5. loss of phase
6. power suitable
7. lamp test (if required)
8. audible(can be switched off) and visible(can not be switched off) alarms
9. LRP

- Two 12 V batteries for diesel engine
- Battery chargers
- Additive alarm signals for diesel driven pumps

1. high motor temperature
2. low oil pressure
3. over speed
4. control is in automatic mode
5. charger lamp
6. failure of 1st battery
7. failure of 2nd battery
8. starting failure
9. failure of battery charger
10. engine running
11. lamp test button (optional)
12. audible(can be switched off) and visible(can not be switched off) alarms

fire pump groups can communicate with building automation systems. But to operate and stop fire pump groups from the control room is not suggested because of safety reasons.

Pressure switches are very important, because they generate "run command". There shall be at least one pressure switch for each pump and at least two for the system.

After the adjustments pressure switches should be locked at the factory. They should be in control panel and not effected from vibrations. Min and max set levels should be adjusted individually.

Fire pumps should operate automatically by pressure switches and also should operate manually by pressing an electric push button or pressing a mechanical handle.

Periodic Tests During Operation

Weekly Automatic Test

The timer which is preset at a certain time of the week, opens the solenoid valve. System pressure decreases due to discharge water and solenoid valve is closed after motor starts running. Pump runs for a period which is already programmed and then stops.

During weekly tests the fire security person is supposed to be at the test area (It is not easy to recognise mechanical failures during automatic test).

Minimum run time is 10 minutes for electric motor driven pumps and 30 minutes for diesel engine driven pumps. Diesel engine controller should generate an alarm signal in case of failure which is 15 seconds of cranking and 15 seconds of rest, in six consecutive cycles.

Weekly Manual Test

After completion of automatic weekly tests, manual-electrical (by pressing a button on controller) and manual-mechanical (by pressing a handle on controller) tests are done for a short period of time.

Monthly and Annual Test

These tests are for the purpose of protective maintenance and defined in NFPA -25

Standart Pompa technical team is ready to help on this matter if required.

Factory Test

Each fire pump is hydrostatically tested 1.5 times of shut off pressure (not less than 17 bars) for a minimum 5 minutes period.

Each fire pump is factory tested as per NFPA-20 requirement.

Fire pump groups and fire booster sets are functionally tested at factory.

Optional Accessories of Fire Pump Group (*)

Standart fire pump groups include all the required elements per NFPA-20.

Optional elements are shown below :

- suction valve position monitoring switch
- suction valve lock
- waste cone
- discharge valve position monitoring switch
- discharge valve lock
- flowmeter at the flow rate 1.75 times of rated flow

(*) **Fire Pump Group** : Main pump, stand-by pump, jockey pump, electric control panels, collectors, valves etc. all on common base plate.

Automatic Weekly Test Algorithm

For Electric Pump

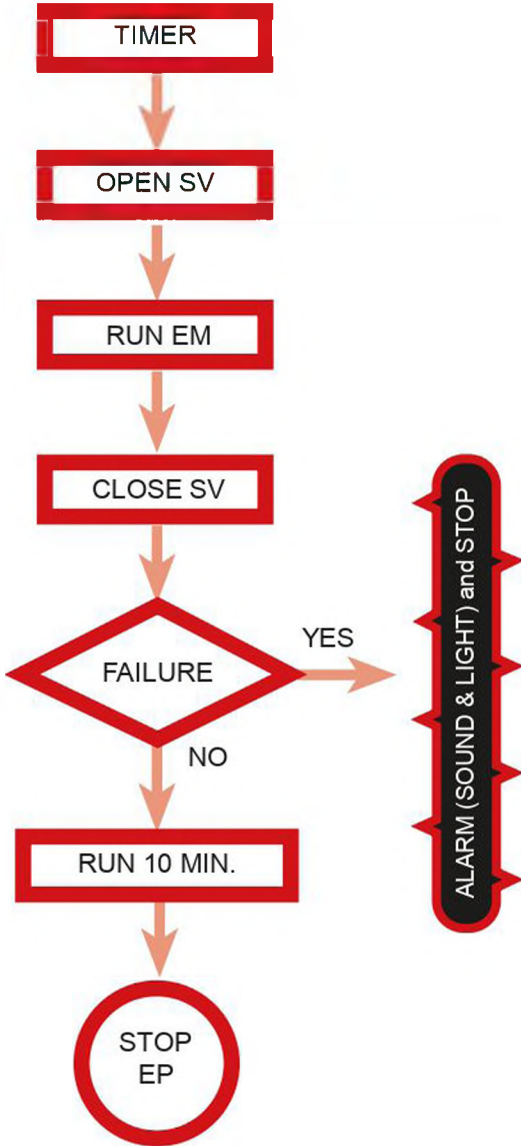

For Diesel Pump

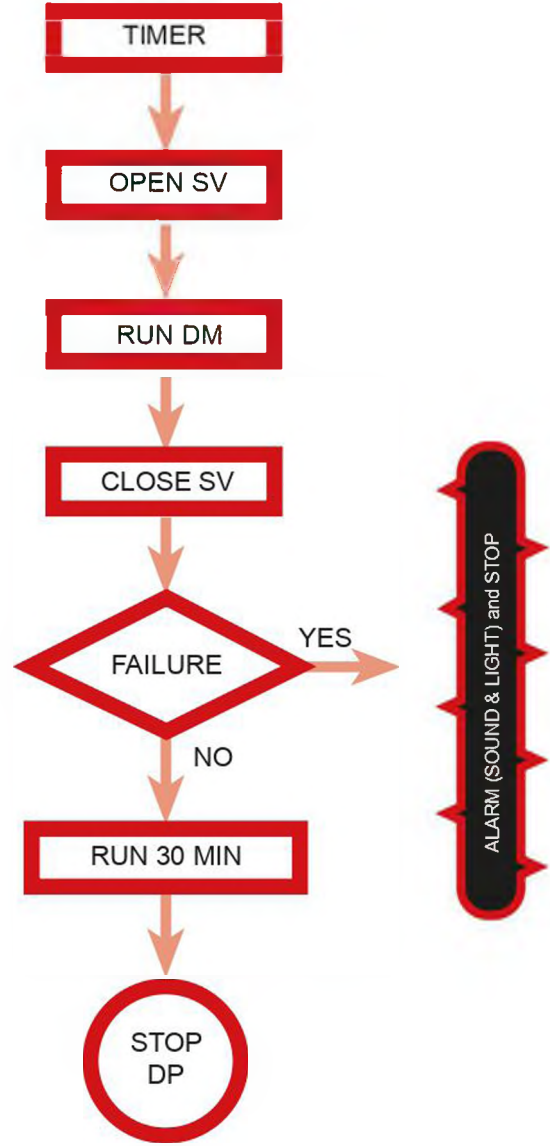

Алматы (7273)495-231
 Ангарск (3955)60-70-56
 Архангельск (8182)63-90-72
 Астрахань (8512)99-46-04
 Барнаул (3852)73-04-60
 Белгород (4722)40-23-64
 Благовещенск (4162)22-76-07
 Брянск (4832)59-03-52
 Владивосток (423)249-28-31
 Владикавказ (8672)28-90-48
 Владимир (4922)49-43-18
 Волгоград (844)278-03-48
 Вологда (8172)26-41-59
 Воронеж (473)204-51-73
 Екатеринбург (343)384-55-89

Россия +7(495)268-04-70

Иваново (4932)77-34-06
 Ижевск (3412)26-03-58
 Иркутск (395)279-98-46
 Казань (843)206-01-48
 Калининград (4012)72-03-81
 Калуга (4842)92-23-67
 Кемерово (3842)65-04-62
 Киров (8332)68-02-04
 Коломна (4966)23-41-49
 Кострома (4942)77-07-48
 Краснодар (861)203-40-90
 Красноярск (391)204-63-61
 Курск (4712)77-13-04
 Курган (3522)50-90-47
 Липецк (4742)52-20-81

Казахстан +7(7172)727-132

Магнитогорск (3519)55-03-13
 Москва (495)268-04-70
 Мурманск (8152)59-64-93
 Набережные Челны (8552)20-53-41
 Нижний Новгород (831)429-08-12
 Новокузнецк (3843)20-46-81
 Ноябрьск (3496)41-32-12
 Новосибирск (383)227-86-73
 Омск (3812)21-46-40
 Орел (4862)44-53-42
 Оренбург (3532)37-68-04
 Пенза (8412)22-31-16
 Петрозаводск (8142)55-98-37
 Псков (8112)59-10-37
 Пермь (342)205-81-47

Киргизия +996(312)96-26-47

Ростов-на-Дону (863)308-18-15
 Рязань (4912)46-61-64
 Самара (846)206-03-16
 Саранск (8342)22-96-24
 Санкт-Петербург (812)309-46-40
 Саратов (845)249-38-78
 Севастополь (8692)22-31-93
 Симферополь (3652)67-13-56
 Смоленск (4812)29-41-54
 Сочи (862)225-72-31
 Ставрополь (8652)20-65-13
 Сургут (3462)77-98-35
 Сыктывкар (8212)25-95-17
 Тамбов (4752)50-40-97
 Тверь (4822)63-31-35

Тольятти (8482)63-91-07
 Томск (3822)98-41-53
 Тула (4872)33-79-87
 Тюмень (3452)66-21-18
 Ульяновск (8422)24-23-59
 Улан-Удэ (3012)59-97-51
 Уфа (347)229-48-12
 Хабаровск (4212)92-98-04
 Чебоксары (8352)28-53-07
 Челябинск (351)202-03-61
 Череповец (8202)49-02-64
 Чита (3022)38-34-83
 Якутск (4112)23-90-97
 Ярославль (4852)69-52-93