

VESTAPOMP

Makes life comfortable

C

C SUBMERSIBLE SEWAGE & WASTE WATER PUMPS

INSTRUCTIONS FOR INSTALLATION, OPERATION & MAINTENANCE



Pump Type	:
Serial No	:
Capacity	:m ³ /h
Head	:m
Motor Power	:kW
Speed	:rpm

Алматы (7273)495-231
Ангарск (3955)60-70-56
Архангельск (8182)63-90-72
Астрахань (8512)99-46-04
Барнаул (3852)73-04-60
Белгород (4722)40-23-64
Благовещенск (4162)22-76-07
Брянск (4832)59-03-52
Владивосток (423)249-28-31
Владикавказ (8672)28-90-48
Владимир (4922)49-43-18
Волгоград (844)278-03-48
Вологда (8172)26-41-59
Воронеж (473)204-51-73
Екатеринбург (343)384-55-89

Россия +7(495)268-04-70

Иваново (4932)77-34-06
Ижевск (3412)26-03-58
Иркутск (395)279-98-46
Казань (843)206-01-48
Калининград (4012)72-03-81
Калуга (4842)92-23-67
Кемерово (3842)65-04-62
Киров (8332)68-02-04
Коломна (4966)23-41-49
Кострома (4942)77-07-48
Краснодар (861)203-40-90
Красноярск (391)204-63-61
Курск (4712)77-13-04
Курган (3522)50-90-47
Липецк (4742)52-20-81

Казахстан +7(7172)727-132

Магнитогорск (3519)55-03-13
Москва (495)268-04-70
Мурманск (8152)59-64-93
Набережные Челны (8552)20-53-41
Нижний Новгород (831)429-08-12
Новокузнецк (3843)20-46-81
Ноябрьск (3496)41-32-12
Новосибирск (383)227-86-73
Омск (3812)21-46-40
Орел (4862)44-53-42
Оренбург (3532)37-68-04
Пенза (8412)22-31-16
Петрозаводск (8142)55-98-37
Псков (8112)59-10-37
Пермь (342)205-81-47

Киргизия +996(312)96-26-47

Ростов-на-Дону (863)308-18-15
Рязань (4912)46-61-64
Самара (846)206-03-16
Саранск (8342)22-96-24
Санкт-Петербург (812)309-46-40
Саратов (845)249-38-78
Севастополь (8692)22-31-93
Симферополь (3652)67-13-56
Смоленск (4812)29-41-54
Сочи (862)225-72-31
Ставрополь (8652)20-65-13
Сургут (3462)77-98-35
Сыктывкар (8212)25-95-17
Тамбов (4752)50-40-97
Тверь (4822)63-31-35

Тольятти (8482)63-91-07
Томск (3822)98-41-53
Тула (4872)33-79-87
Тюмень (3452)66-21-18
Ульяновск (8422)24-23-59
Улан-Удэ (3012)59-97-51
Уфа (347)229-48-12
Хабаровск (4212)92-98-04
Чебоксары (8352)28-53-07
Челябинск (351)202-03-61
Череповец (8202)49-02-64
Чита (3022)38-34-83
Якутск (4112)23-90-97
Ярославль (4852)69-52-93

Contents

CONTENTS	i
GENERAL INSTRUCTIONS	ii
IDENTIFICATION OF SAFETY AND WARNING SYMBOLS	ii
SAFETY INSTRUCTIONS	ii
A- GENERAL	1
A1- Description of Pump	1
A2- Application Areas	1
A3- Pump Designation	1
A4- Pump Name Plate	1
B- UNCRATING, TRANSPORT AND STORAGE	2
B1- Uncrating	2
B2- Transport	2
B2.1- General Recommendations	2
B2.2- Lifting	2
B3- Storage	2
C- GENERAL DESIGN	3
C1- Motor	3
C2- Pump	3
D- INSTALLATION	5
D1- Types of Installation	5
D2- Connecting the Piping	8
D3- Electrical Connections	8
D3.1- General Recommendations	8
D3.2- PCST3-V2 Motor Protection and Control Relay	8
E- START UP - SHUT DOWN	9
E1- Checking the Direction of Rotation	9
E2- Start Up	10
E3- Shut Down	10
E4- Starting Frequency	10
F- MEINTENANCE AND LUBRICATION	10
F1- Periodical Controls	10
F1.2- Control of the Motor Casing	11
F1.3- Checking the Cable Inlet	11
F1.4- Checking the Mechanical Seal	11
F2- Lubrication and Grease Change	11
G- DISMANTLING REPAIR AND REASSEMBLY	11
G1- Preparation	11
G2- Dismantling the Pump	12
G3- Reassembling the Pump	12
H- SPARE PARTS	13
I- FAULTS AND CAUSES	13
J- DISASEMBLY DRAWINGS	14

This manual is intended to be a reference guide for users of pumps providing information on

- Pump installation and maintenance instructions,
- Pumps start-up, operation and shut - down procedures.

IDENTIFICATION OF SAFETY AND WARNING SYMBOLS



Safety instructions in this manual which could cause danger to life if not observed.



The presence of a dangerous electric current.

ATTENTION Non – observance to this warning could damage the machine or affect its functions.

GENERAL INSTRUCTIONS



- **This manual should be kept in a safe place and ALWAYS be available to the QUALIFIED operating and maintenance personnel responsible for the safe operation and maintenance of the pumps.**

- Qualified personnel should be experienced and knowledgeable of safety standards.
 - To avoid faulty operation and malfunctioning of pumps the instructions in this manual are to be CAREFULLY studied and followed at all stages of the pump installation and operating life.
 - The user is responsible for ensuring that inspection and installation are carried out by authorized and qualified personnel who have studied this manual carefully.
 - The pump should be used ONLY in the operating conditions given on the order for which the pump and materials of the construction have been selected and tested.
 - If the pump is to be used for a different application please contact sales office or representative of the manufacturer. refuses to assume any responsibility if the pump used for different applications without prior written permission.
 - If the pump is not to be installed and operated soon after arrival, it should be stored in a clean and dry place with moderate changes in ambient temperature. Extreme low or high temperatures may severely damage the pump unless suitable precautions are taken. The user is responsible for the verification of the ambient conditions where the pump will be stored or installed.
 - does not guarantee repairs or alterations done by user or other unauthorized personnel.
- The use of original spare parts and accessories authorized by manufacturer will ensure safety.
- This manual does not take into account any site safety regulation, which may apply.

SAFETY INSTRUCTIONS



Strictly obey to the following instructions to prevent personal injuries and/or equipment damages:

- Pump should be used only in the specified operating conditions.
 - Any weight, stress or strains on the piping system should not be transmitted to the pump.
 - Electrical connections on the motor or accessories must always be carried out by authorized personnel and in accordance to the local codes.
 - Any work on the pump should be only carried out when the unit has been brought to standstill.
- 
- **Always disconnect the power to the motor and make sure not be switched on accidentally before working on the pump or removing the pump from installation.**
 - Any work on the pump should be carried out by at least two persons.
 - When approaching the pump always be properly dressed and/or wear safety equipment suitable for the work to be done.
 - Do not work on the pump when it is hot.
 - Do not touch the pump or piping with temperatures higher than 80 °C. User must take suitable precaution to warn the persons (e.g. using warning signs, barrier).
 - Always be careful when working on pumps that handling dangerous liquids (e.g. acids or hazardous fluids).
 - Do not work on the pump when the pump and piping connected to the pump are under pressure.
 - After completion of the work always fix the safety guards back in places previously removed.
 - Do not run the pump in the wrong direction of rotation.
 - Do not insert hands or fingers into the pump openings or holes.
 - Do not step on the pump and/or piping connected to the pump.

C TYPE PUMPS

A- GENERAL

A1- Pump Description

C type submersible pumps for wet installation are single stage, single entry, close coupled pump sets in non-flameproof design.

A2- Applications

Depending on the hydraulic end, the pump is intended to be used for pumping of

- Domestic wastewater
- Sewage disposal
- Dirty and muddy water
- Industrial wastewater
- Rain water
- Ground water

A3- Pump Designation

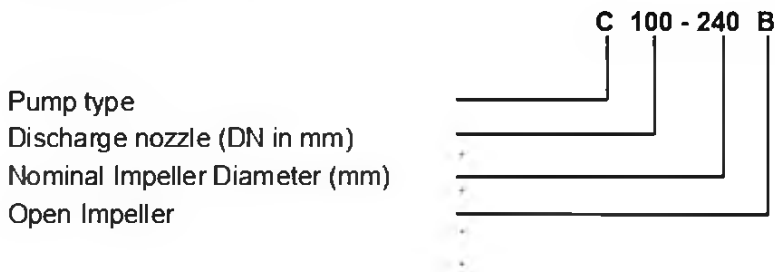

A4- Pump Name Plate

- All pumps can be identified by the Nameplate located on the top cover of the motor.
- Nameplate includes information about operating conditions.

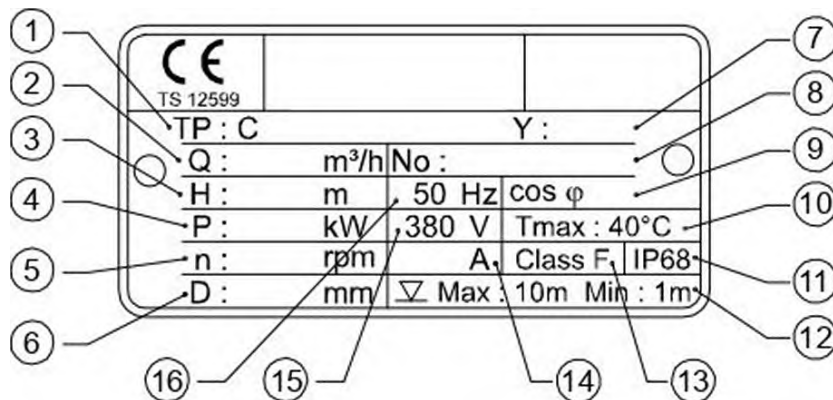

- | | |
|-----------------------|------------------------------|
| 1- Pump Type and Size | 9- Power Factor |
| 2- Capacity | 10- Max. Ambient Temperature |
| 3- Head | 11- Protection Class |
| 4- Motor Power | 12- Max. Submergence |
| 5- Speed | 13- Insulation Class |
| 6- Impeller Diameter | 14- Current |
| 7- Year | 15- Voltage |
| 8- Serial Number | 16- Frequency |

B- UNCRATING, TRANSPORT AND STORAGE

B1- Uncrating

- Upon receipt verify that the goods received are in exact compliance with that listed on the packing list.
- Check that no visible damage exists on the crate that could have occurred during transportation.
- Carefully remove the packaging material and check that pump and accessories (if any) are free from any markings, stretches and damages, which may have occurred during transportation.
- In the event of damage report this immediately to service department and to the transport company.

B2- Transport

B2.1- General recommendations



- Existing regulations for the prevention of accidents must be followed.
- Wearing of gloves, hard-toed boots and hard hats is obligatory for all transport works.
- Wooden cases, crates, pallets or boxes may be unloaded with fork-lift trucks or using hoisting slings, depending on their size, weight and construction.

B2.2- Lifting

- Prior to lifting and moving the pump or pump and motor on a common base plate find out the following:
 - Total weight and center of gravity
 - Maximum outside dimensions
 - Lifting points location
- The load-bearing capacity must be proper to the weight of the pump or the pump set.
- The pump or pump set must always be raised and transported in horizontal position.
- It is absolutely forbidden to stand beneath or nearby a raised load.
- A load should never remain in a raised position for longer than necessary.

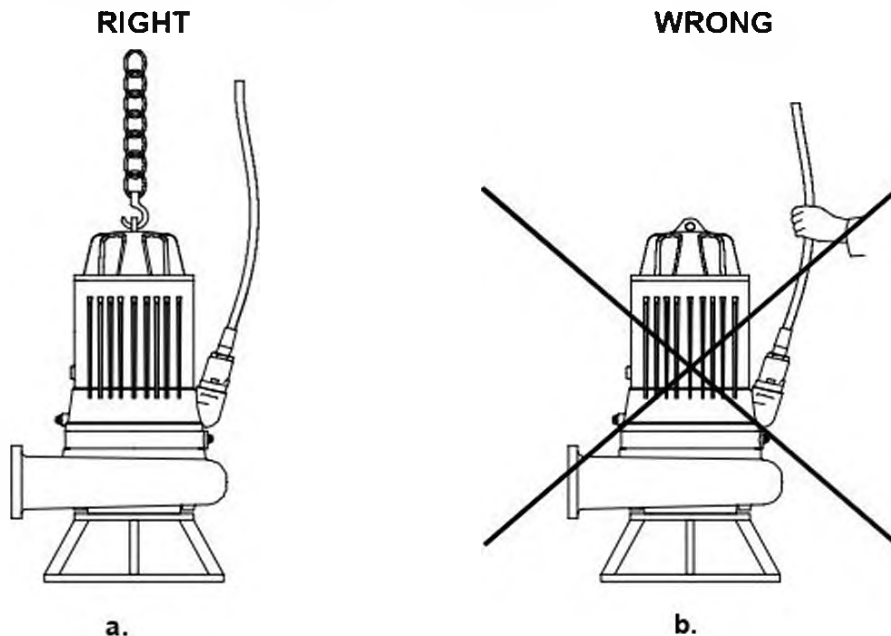

Figure 1. Lifting the pump properly

B3- Storage

- If the pump is not to be installed and operated soon after arrival, store the pump in a clean, dry and frost-free place with moderate changes in ambient temperature.
- To prevent the pump from moisture, dust, dirt and foreign materials suitable steps should be taken.

C- GENERAL DESIGN

C Type Submersible sewage pumps are developed for the purpose of pumping domestic and industrial waste water containing large solid particles. These pumps are suitable for operating entirely immersed in water. Different types of impeller are used in **C Type** pumps for different purposes of pumping clean and waste water, sewage containing solids and fibrous materials, faecal material and sludge.

C1- MOTOR

Speed	: 2900 rpm (50 Hz) 3500 rpm (60 Hz)
Power	: Single Phase up to 1.5 kW Three Phase up to 11 kW
Insulation Class	: F (155 °C)
Protection Class	: IP 68
Cooling Method	: External water cooling

BEARINGS

Rotor and impeller are on the same shaft. The shaft is supported by two heavy duty ball bearings, which are maintenance free for two years operation.

SHAFT SEALING

High quality silicon carbide to silicon carbide mechanical seals, which operate in oil bath, are used between the motor and pumping liquid. By any reason if any water leakage occurs into the oil bath, the built-in monitoring system stops the motor by transmitting signals. Therefore it does not harm the motor. There are two lip-seals between oil bath and motor housing.

THERMAL CONTROL SYSTEM

submersible motors are manufactured suitable for operating immersed in the water, incase the motor casing stays outside the water, it is natural that the motor starts heating up after certain period. For such a case built-in 130 °C thermistors are placed on the stator windings in order to protect the motor. Leakage and motor heating signals are transmitted to the PCST3-V2 protection and control relay of the Motor-Control panel on the surface by means of auxiliary conductors of the energy cable.

CABLE CONNECTION

All sizes of Submersible motors start up directly (NOT STAR-DELTA). Therefore only three pieces of energy conductors are enough (U-V-W). There are also three energy cables on the single phase motors (M1-Phase, M2-Earth return and A-Capacitor conductors). Four smaller size conductors are used for protection and control (E-T-T-Mp). Energy and control cable connections are done by means of a water proof socket system. Inlet points of the motor casing and cable are protected by insulating resin.

C2- PUMP

C type pumps are consist of 6 casing sizes, discharge diameters are $\varnothing 50$, $\varnothing 80$ and $\varnothing 100$ mm (2", 3" and 4"). Different impellers are used in these models depending on the pumping liquid, pressure, size of the solid particles and capacity of the pump.

B type impeller : Closed type impellers with wide channels capable of pumping large size solid particles without clogging, for big capacity and low pressure. It is more suitable for 4 pole motors (1450 or 1750 RPM).

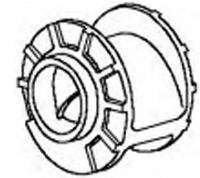

D type impeller : It is also closed type, suitable for high speed motors (2900 or 3500 RPM). It is convenient for high pressure, small capacity and smaller size solid particles.



VX type impeller : Free vortex type semi-open impeller is placed on top of the volute. It can pump the solid particles without touching them. It is also suitable for fibrous materials.



F type impeller : Semi-open type impeller with cutter. The cutting system is placed in front of the impeller and it breaks up the solid particles into smaller sizes that makes passing possible through the smaller pipes without sticking. F type impeller suitable for small capacity, high pressure, but the pump efficiency is also low.

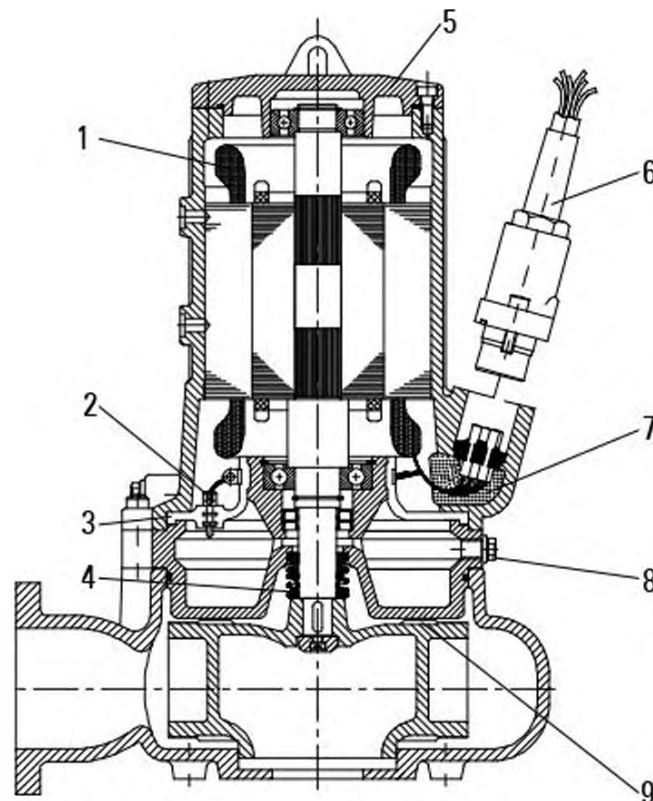
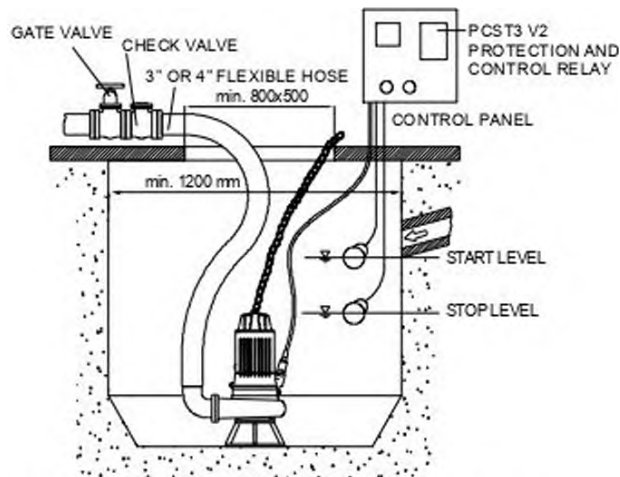
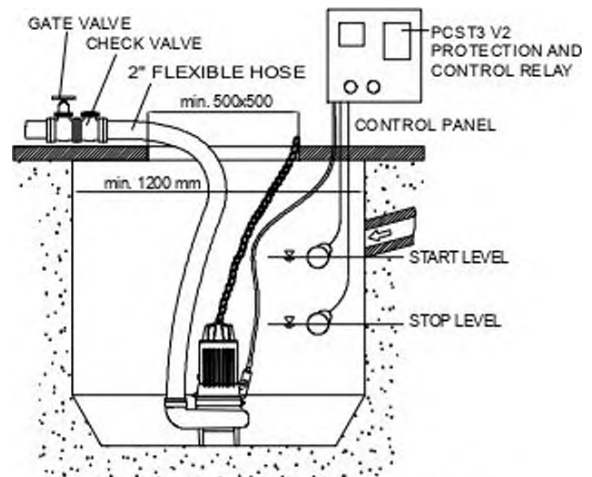

Figure 2. Sectional drawing for basic design

- 1- Temperature SENSOR (130°C) in F class winding head protection for overheating.
- 2- Signaling ELECTRODE in case of leakage into the motor or into the oil chamber.
- 3- RUBBER BELLOWS balancing the pressure between the motor and oil chamber.
- 4- Silicon-Carbide MECHANICAL SEAL running in oil bath.
- 5- Demountable TOP COVER for easy motor winding.
- 6- Water tight CABLE CONNECTION demountable male and female socket.
- 7- INSULATING RESIN in order to secure definite sealing.
- 8- Oil filling and inspection PLUGS.
- 9- BACK VANES for reducing axial load and sealing pressure.



HOSE CONNECTION FOR C 80 & 100 SIZE PUMPS



HOSE CONNECTION FOR C 50 SIZE PUMPS

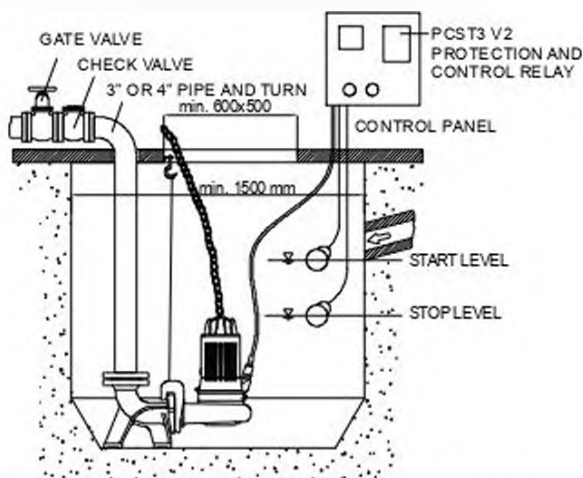

GUIDE - WIRE CONNECTION FOR C 80 & 100 SIZES PUMPS

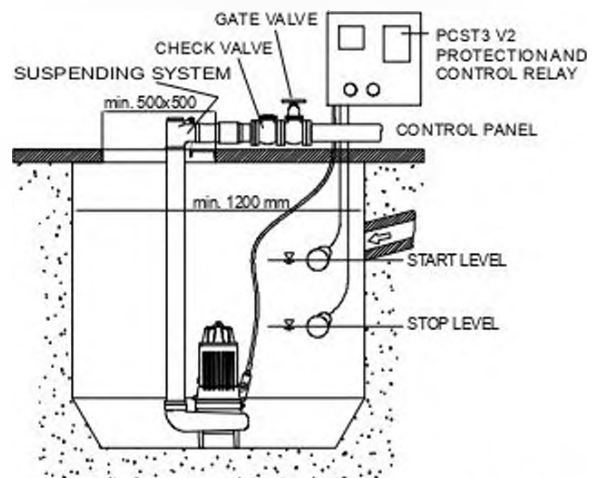

SUSPENDED CONNECTION FOR C 50 SIZE PUMPS

Figure 3. Types of installation of the pump to the sump

D- INSTALLATION OF THE PUMP

D1- TYPES OF INSTALLATION

C Type submersible pumps can be installed in three different ways according to application place and purposes. When ordering the pump, installation place and the purpose or the type of installation should be indicated and the necessary accessories should be purchased together with the pump.

1- HOSE CONNECTION: In this kind of application the pump is sat on the base of the sump. Water is pumped up to the surface by a flexible hose and can be connected to a pipe system if necessary. The pump is lowered to the sump by means of a chain. Hose connection can be applied to all sizes of C type pumps. In this application the bottom of the sump should be flat and solid (in order to make the pump not to sink but to stay vertically). Necessary auxiliary parts for this application: Hose connecting union, elbow, sit-on-foot and riser chain.

2- SUSPENDED CONNECTION: The pump is hanged to the inlet of the pipe system on the ground by a special connecting device. Pump does not sit on the base of the sump. If required, the connection elbow can be used as a non-return valve. Suspended connecting can be applied only for $\varnothing 50$ mm (2") size pumps. It is not necessary for sump bottom to be flat and solid for suspended connection. Suspension elbow and complete suspension set are needed for this application. In request, suspension pipe can be supplied by our factory. Suspension elbow can also be ordered with check-valve.

3- GUIDE WIRE CONNECTION: In this application there should be a coupling pedestal, a riser pipe and a guide wire previously placed at the bottom of the sump. Pump is placed on the guide wire at the top, then to be lowered by means of a chain and when it touches the coupling pedestal it is automatically coupled to the discharge pipe system. In this application the pump does not sit on base either. This application can be applied for $\varnothing 80$ - $\varnothing 100$ mm (3" - 4") pumps. For guide wire connection, the coupling pedestal and the discharge pipe should be installed when the sump bottom is dry (during construction). If this installation is done later on, the system may not be durable enough.

Necessary auxiliary parts for this application: Coupling pedestal, guide wire, stretching device, riser pipe in enough length and guide wire in enough length.

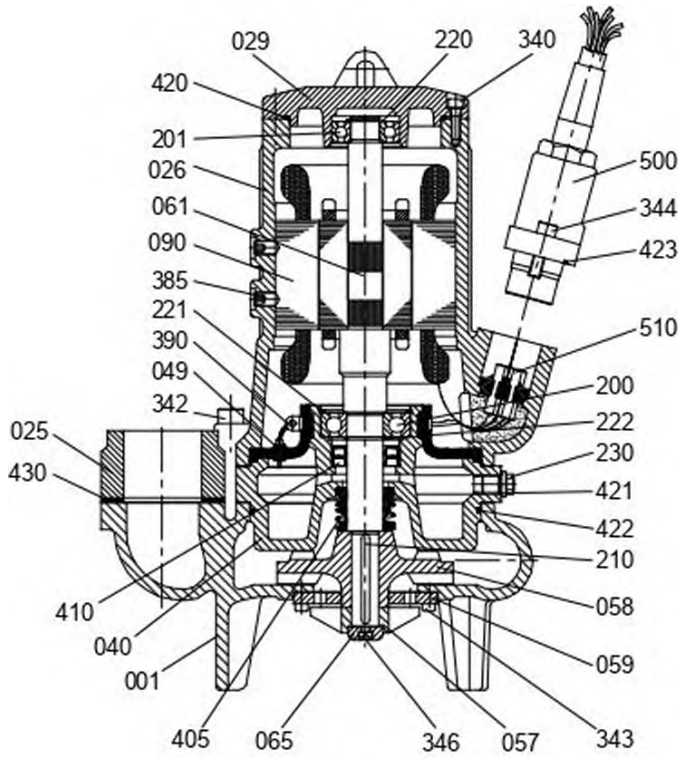

C 50-160 F

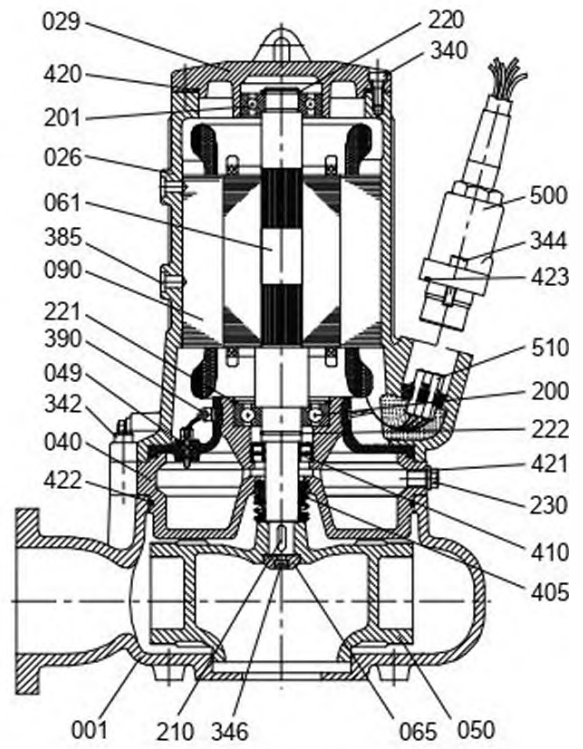

C 80-200 D

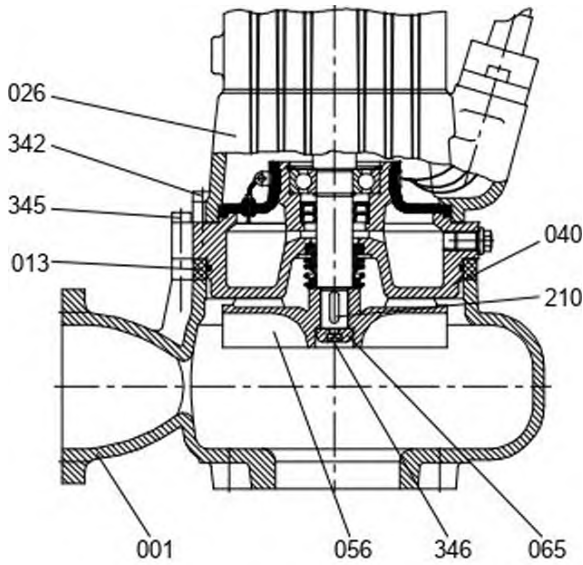

C 100-270Vx

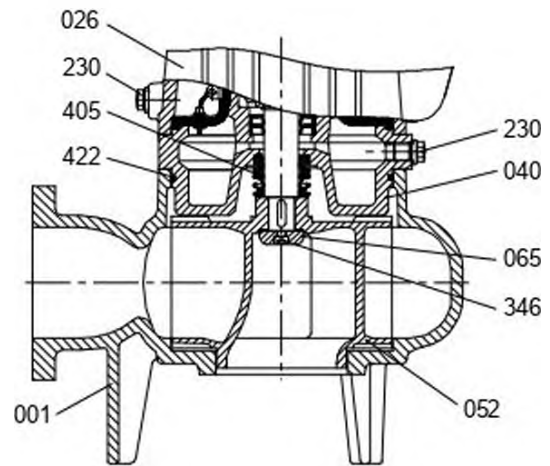

C 80-160 B

PART LIST

001	Volute Casing	058	F Type Impeller	230	Oil Plug	420	O-Ring
013	Spacer Part	059	Fixed Cutter	340	Allen Bolt	421	O-Ring
025	Special Flange	061	Rotor Shaft	342	Allen Bolt	422	O-Ring
026	Motor Casing	065	Impeller Nut	343	Allen Bolt	423	O-Ring
029	Top Cover	090	Wound Stator and Rotor Set	344	Allen Bolt	430	Rubber Gasket
040	Oil Chamber	200	Bottom Bearing	345	Allen Bolt	500	Energy and Control Cable with Plug
049	Rubber Bellows	201	Top Bearing	346	Allen Bolt		
050	D Type Impeller	210	Impeller Key	385	Set Screw		
052	B Type Impeller	220	Shaft Retaining Ring	390	Clip	510	Plug Set
056	Vx Type Impeller	221	Bearing Retaining Ring	405	Mechanical Seal		
057	Rotating Cutter	222	Shaft Retaining Ring	410	Oil Seal		

CIRCUIT DIAGRAMS FOR MOTOR CONTROL PANEL

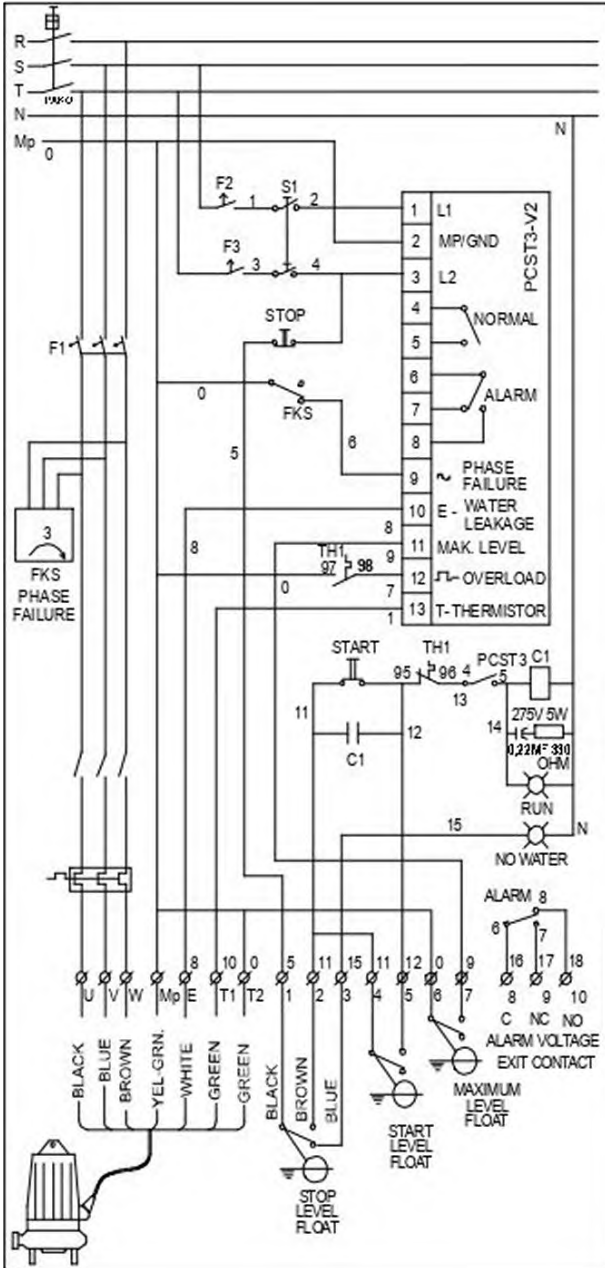

PUMPS WITH THREE-PHASE MOTORS

Cable sizes according to motor powers

- Up to 0.75kW (4 x 1.5 + 3 x 1.5)
- 11kW (3 x 2.5 + 4 x 1.5)

NOTE: Please connect 1 to 2 for manual operating (without float switches)

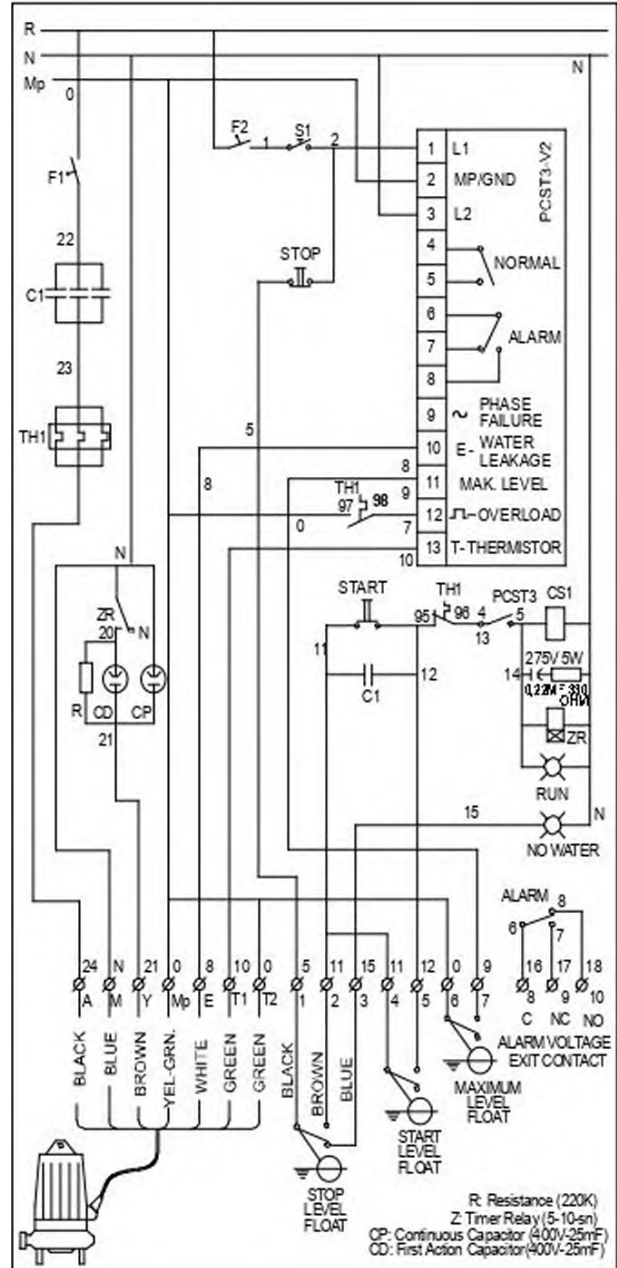

PUMPS WITH SINGLE-PHASE MOTORS

Cable sizes according to motor powers

- For 1.5 kW (3 x 2.5 + 4 x 1.5)

D2- Connecting The Piping

D2.1- Hose connection: A check-valve should be used right after the pump discharge hose connection point which is on the ground level, A control valve should also be used if the discharge pipe is long. Hose-discharge pipe connection should be an easily dismantling type.

D2.2- Suspended connection: Discharge pipe is connected directly to the coupling pedestal which is supplied together with the pump for the suspended connection. If the check-valve is with connecting elbow, there is no need for a separate check-valve provided that a gate valve must be placed at the outlet and it should definitely be closed during dismantling the pump from where it is installed. If the connecting elbow is without check-valve, a check-valve and a gate valve should be used after coupling pedestal.

D2.3- Guide wire connection: For guide wire type connection; discharge pipe, guide wire system, gate valve and check-valve should be installed together with coupling pedestal during construction.

D2.4- General rules to be followed during pipe connections:

- Horizontal pipes must have the rising slope towards to the flow direction as much as possible.
- Pipe dimensions must be at least equal to the pump discharge dimensions. Pipe dimension must be chosen in a way that the flow velocities are between 1.5 – 3 m/s in order to avoid precipitation (caused by low flow velocity) and extreme head losses (caused by high flow velocity).
- Do not use sharp bends and elbows with narrow passages, make sure the pipe inner surface is smooth and clean to avoid solid particles cause clogging.

D3- Electrical Connections

D3.1- General recommendations



1. All electrical works must be done by qualified electricians. All main electrical equipment must be earthed. Failure to heed this warning may cause lethal accident. Make sure that the earth lead is correctly connected by testing it.

ATTENTION

2. Use Standart PCST3-V2 Motor Protection and Control Relay which is supplied with the pump. We do not guarantee the pumps running without PCST3-V2 relay.

3. Motor Control Panels must be manufactured according to the circuit diagrams in this booklet. If you use a different circuit diagram, please contact our technicians and have their approval.

4. Make sure the currents and cable diameters of contactors, overload relays and fuses are suitable for motors nominal currents.

5. Check the mains voltage and be sure it corresponds to the value on motor label.

6. Check the connection of motor cable socket and secure the tightness before initial operation.

7. Connect the energy and control cable to the motor control panel complying with the colors and diameters stated in the diagrams.

8. Make sure the outer cover of the energy cable is protected against damages that might be caused by sharp metal or concrete corners and prevent it from being squeezed in narrow spaces.

ATTENTION

Do not use the cable to lift the pump.

D3.2- PCST3-V2 MOTOR PROTECTION AND CONTROL RELAY

Standart PCST3-V2 Motor Protection and Control Relay is an indispensable part of Standart C type pumps. It is supplied with the pump and it shall be used to secure smooth operation of motor and the pump.

FUNCTIONS

When the device is switched on, all indicator lights blinks in order and the control unit makes a self-check. If there is not any failure, NORMAL indicator light switches on in green indicating it is ready to run the motor.

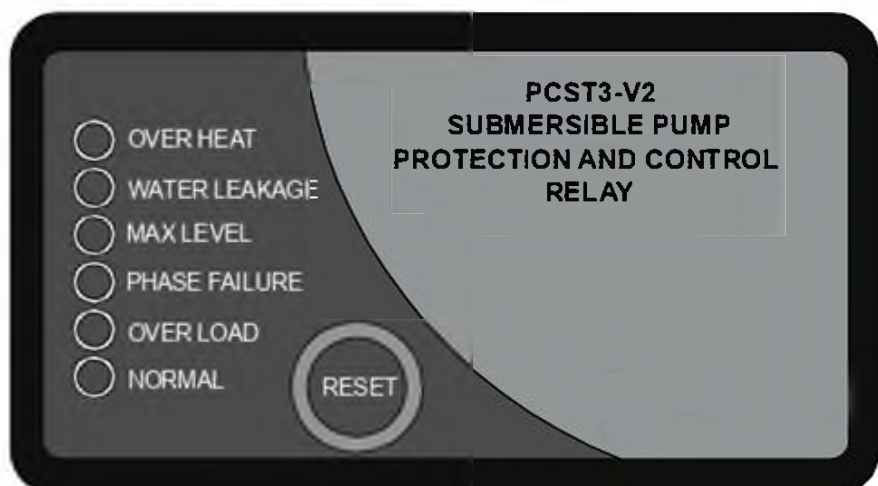

OVER HEAT

In case of overheating of motor windings, in which the temperature exceeds 130°C, the red indicator light switches on and the relay shuts down the motor. Indicator light blinks in short periods at alarming position. When motor has cooled down, relay restarts the motor while alarming goes on until the RESET button is pressed. Pressing the RESET button disables the alarm relay and indicator light stops blinking.

WATER LEAKAGE

In case of water leakage into the motor casing or oil chamber, red indicator light switches on and the relay shuts down the motor. Alarm relay becomes activated and until the RESET button is pressed, alarming goes on by blinking of red indicator light in short periods. **When this failure occurs, the pump needs to be overhauled.**

MAX LEVEL

When water level reaches the maximum level, which is set by the user, float switch sends on alarm signal and yellow indicator light starts blinking. This alarm does not affect the current state (run or stop) of the pump. Pressing the RESET button disables the alarm relay and indicator light stops blinking.

PHASE FAILURE

An external phase protection relay, mounted in the control panel, is connected to PCST3-V2 for checking phase sequence and phase failures. When there is a failure in mains voltage or in phase sequence, the motor is shut down by the relay and red indicator light starts blinking. By the time the failure is fixed, the motor restarts automatically while alarming goes on until the RESET button is pressed.

OVERLOAD

The relay shuts down the motor, if the current overload limit is exceeded. Meanwhile, alarm relay becomes activated and red indicator light starts blinking. As the failure is fixed, pressing the RESET button will disable the overload and the alarm relay, so the system turns back to normal conditions.

NORMAL

By the time all red indicator lights on PCST3-V2 switch off, green indicator light switches on, meaning that it is ready to run the motor. In case of failure, green indicator light switches off and the relay shuts down the motor.

PCST3-V2 is an indispensable part of Standart C type pumps. If it is damaged, do not try to operate the motor without it.

E- START UP – SHUT DOWN

E1- Checking The Direction of Rotation

All types and of Submersible Waste Water and Sewage Pumps rotate in clockwise (CW) direction viewed from the top. If all the electrical connections are done according to the instructions given in sections B3, the pump will rotate in the right direction. However, **it is strongly advised to check the direction of rotation before installation of the pump down in the sump.** To check the direction of rotation, while the pump is suspended in the air, first press the start button and then quickly press the stop button. Although the impeller can not be seen, direction of the casing's reaction can be observed.

There are 3 situations;

- 1- If the reaction of the casing is in Counter Clock Wise (CCW), the direction of rotation is correct (CW). Electrical connections are done in the right way. Pump can be installed to the sump.
- 2- If the reaction of the casing is in clock wise (CW), the direction of rotation is incorrect (CCW). To fix the problem, the position of two motor cables to the panel must be exchanged. Please recheck the direction of rotation after exchange.
- 3- When the start button is pressed, if the contactor on the panel is not energized, PHASE FAILURE light is blinking and the motor is not running, whether there is a phase sequence failure or one of the phases is not energized. Make sure that all three phases one energized. Then, check for the phase sequence. The correct sequence is to be set according to direction of rotation.

REVERSE ROTATION

Reverse rotation of the impeller will cause undesirable problems like increase in power consumption, decrease in performance, loosening of impeller nut, scraping caused by impeller contact with casing, and etc. Therefore, before installation of the pump in the sump, the direction of rotation must be checked. Reverse rotation is not a case for single phase motors.

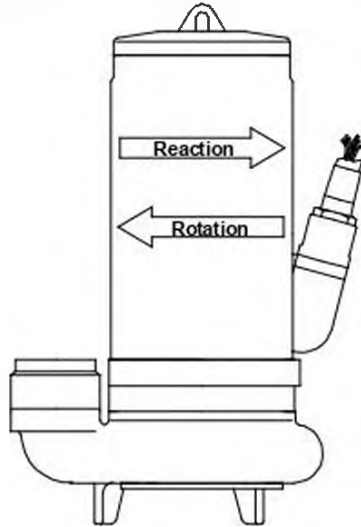

E2- START UP

When the control panel is energized, make sure that green indicator light (NORMAL) is switched on. This indicates there is not any failure and the electrical connections are done in the right way. Pressing the START button or increasing of water level to the set level will start up the motor.

E3- SHUT DOWN

The motor can be shut down manually by pressing the STOP button. The motor will also automatically stop when the water level drops below the minimum set level. If another application will be used instead of Level Controlled Automatic Starting System, please have Pompa's approval for changed electrical diagram. Standart Pompa refuses to assume any responsibility if the pump used for different applications without prior written permission.

E4- STARTING FREQUENCY

In order to avoid intolerably high temperature rises within the motor, and excessive overloading of the motor, seals and bearings a **maximum of 20 evenly spaced starts per hour** is allowed.

F- MAINTENANCE AND LUBRICATION

STANDART PCST3-V2 RELAY stops the pump and warns the type of fault when it is used with **C type** submersible pump. But it is better to make periodical maintenance at certain times for avoiding the probable faults; especially it is important to inspect wear in mechanical seal and the water leakage at the beginning.

F1- PERIODICAL CONTROLS

Please checks the pump for oil and leakage at the end of the first week and the first month by taking the pump out of the sump. If there is not any unusual situation in these controls, consequent controls can be done once a year. If the pumping liquid is dense, corrosive or hazardous you must make periodic controls more frequently.

F1.1- CONTROL OF THE MOTOR CASING

1. submersible motor has three control plugs. Two of them are on the opposite sides of the oil chamber. The third one is at the bottom of the motor casing.
2. Check the tightness of the plug on the motor housing by applying a torque on it. Then unscrew and take off the plug. Turning the motor as the plug hole comes facing the floor, check whether any water or oil comes out of the plug hole.
3. If some water comes from the plug hole of the motor casing, it means that there is a gasket fault. But if there is PCST3-V2 relay in the motor control panel, "WATER LEAKAGE" light points this and will stop the motor earlier.
4. If some oil comes out from this plug hole, this means that, oil seals between oil chamber and motor casing are damaged. They must be changed.

F1.2- CHECKING THE CABLE INLET

1. **STANDART** submersible motor is connected to energy and control cable by special water tight demountable male and female socket type system. Male socket is on the motor casing to secure a complete sealing. The motor casing and inside of the plug are filled with insulating resin.
2. In order to check the socket system, first clean the motor casing especially male and female sockets area and dry them. Then unscrew the two connecting bolts and plug. Check the sockets to see if there is any water inside.
3. Change o-ring and plug. Make sure the gasket is placed firmly and the bolts are tightened well.

F1.3- CHECKING THE MECHANICAL SEAL

1. Lay down the motor at which one of the two oil plugs is upside and the other is downside.
2. Open oil plugs and empty the oil into a clean pot.
3. If the oil is clean and clear, it means the mechanical seal is in good condition. The same oil can be used again.
4. If the oil is in yellow-gray color or it is mixed with water, it shows the mechanical seal is worn out and it needs to be changed. In this case the WATER LEAKAGE light will be off on the motor control panel and the motor will stop.

If the results of these four stages are positive, you can take down the pump into the sump.

F2- LUBRICATION AND GREASE CHANGE

1. Motor bearings are grease lubricated type. They are filled up with grease before dispatch. The grease should be changed after 3000 hours working or two years. It is useful to change the grease, if the pump is dismantled for any reason.
2. Use high quality lithium soap grease for ball bearings.
3. The oil in the oil chamber which is needed for lubricating the mechanical seal must be SAE20/SAE30 quality.
4. Before changing the oil clean inside of the oil chamber and wash it with a cleaning solvent.

MOTOR POWER (kW)	RPM	PUMP TYPE	OIL QUANTITY (lt)
0.75 - 1.1 - 1.5 0.75 - 1.1 - 1.5 - 2.2	1450 2900	C 50-160 C 80-160	0.6
0.75 - 1.1 - 1.5 0.75 - 1.1 - 1.5 - 2.2	1450 2900	C 50-200	1.3
2.2 - 3 - 4 3 - 4	1450 2900	C 80-200 C 50-200	1.4
4	1450	C 100-240	2.0
5.5 5.5 - 7.5	1450 2900	C 100-240 C 100-240	2.4
7.5 - 11	1450	C 100-270	2.75

Table 1. Oil amount according to motor type and power

MOTOR POWER (kW)	RPM	BOTTOM BEARING	GREASE cm ³	TOP BEARING	GREASE cm ³
0.75 - 1.1 - 1.5 0.75 - 1.1 - 1.5 - 2.2	1450 2900	6305 C3	10	6204-ZR	6
3 - 4 - 5.5 4 - 5.5	1450 2900	6306 C3	14	6305-ZR	10
7.5 - 10 - 12 7.5 - 10	1450 2900	6307 C3	20	6306-ZR	14

Table 2. Bearing types and grease amount according to motor type and powers

G- DISMANTLING, REPAIR AND REASSEMBLY

STANDART C Type Submersible pump shall be taken to overall maintenance after two years of operation or when a water leakage fault occurs.

G1- PREPARATION

It is advisable that dismantling and repairing of C type pumps should be made in a workshop rather than the pump station. Take out pipe connections of the pump. Clean the outside surfaces of motor and the pump. Detach the cable socket from the motor by unscrewing the two bolts of energy and control cable. As a precaution, switch off the circuit breaker in the panel. Carry the pump to the workshop.

G2- DISMANTLING THE PUMP

G2.1- Take out three of the oil and control plugs (230) which are located on the oil chamber (040) and motor (026). Completely empty the oil inside.

G2.2- Detach the volute casing (001) from the motor (026) by unscrewing the four bolts (342 or 345) (Remember taking off the cutter (057-058-059) on F - type previously).

G2.3- Take off the pump impeller (050) by unscrewing the impeller nut (065). Use rust remover solvent if necessary during dismantling.

G2.4- Be careful when taking out the rotating part of the mechanical seal (405). Do not use sharp edged or cutting tools which may tear the rubber bellow of the mechanical seal.

G2.5- Take out top cover (029) of the motor by unscrewing the four bolts (340). During this operation top ball bearing (201) remains still on the rotor (061) therefore the top cover (029) should be carefully opened by using screw drivers.

G2.6- Turn the motor upside down. Place it on a soft flat surface. Take out the bolts (342) which connect oil chamber and motor. (There are only pin screws (395) on the pumps where volute casing and motor diameter is equal and four regular bolts and two pin screws (395) on the others.)

G2.7- Open up the oil chamber (040) slightly and take off cable connection of water leakage warning electrode which is on the rubber bellow. Use a screw driver for this operation.

G2.8- Take out the oil chamber (040) with rotor bearings (200) and rubber bellows (049). Be careful not to damage the stator windings (090).

G2.9- Take out the retaining ring (221) of bottom bearings by using a strong pliers. Pull off the bottom bearing (200) from oil chamber by stroking it on a wood block.

G2.10- Pull off the top (201) and bottom (200) ball bearings by taking the retaining rings (220 and 222) in front of them.

G2.11- Take out the rubber bellow (049) by unscrewing the clip (390) which tightens the bellow.

G2.12- Take out two oil lip seals and stationary part of mechanical seal (405) by using plastic or wooden tools.

G2.13- Now, all of the pump and motor parts are dismantled. Clean all parts, replace damaged or worn-out ones.

G2.14- If stator windings are burnt out or are damaged, it is needed to rewind them. For this operation first you must break the insulation resin in which the male cable socket is placed. And after repairing the windings, the insulation resin must be refilled. This is a difficult job therefore it must be done by the experts or the complete pump set must be sent to Repairing Workshop.

G3- REASSEMBLING THE PUMP

G3.1- Before starting the reassembly, review all the pump parts, particularly the ones listed below;

- 1- Make sure the two faces of mechanical seals are in good condition without any scratch or dent. Replace them with the new ones if needed.
- 2- Clean the ball bearings and check for any wear. Replace them if needed.
- 3- Gasket and o-ring seating faces should be checked and be rectified if they are damaged.
- 4- Check the shaft for any wear on the sections where ball bearings, mechanical seal and oil ring is in contact. This wear must be eliminated. If not possible then the complete shaft must be changed.
- 5- Check the energy and control cable for any tear or crush. Change it if necessary.
- 6- Stator windings should be tested for insulation with a minimum of 500 Volts.
- 7- Impeller and casing wear rings should be controlled for wear. If the gap between impeller and wear ring is more than 1 mm, a new wear ring shall be mounted to the casing and it shall be rectified in suitable dimension.

G3.2- For reassembling the motor pump, you may find general practical technical information and bellow drawings useful.

G3.3- Reassemble the pump with care by following the reverse sequence of dismantling. Use liquid dishwashing detergent while placing to mechanical seal for easy mounting of rubber gasket and bellow. Do not use oil.

G3.4- After the completion of reassembly refill the oil chamber with oil according to instructions given on section D2. Tighten oil plugs firmly.

G3.5- Plug the cable, tighten the bolts. Turn the pump impeller by hand to check its tightness. Before lowering the pump into sump check again the direction of rotation. Connect it to the discharge pipe and lower into the sump.

H- SPARE PARTS

H1- guarantees to supply the spare parts for C type pumps for 10 years from the date of manufacture. You can provide any spare parts easily.

H2- Let us know the following details on the name plate, when you order spare parts.

Pump Type and Sizes	: (C 50-200Vx)
Motor Power and Speed	: (4 kW - 2900 rpm)
Prod. Year and Serial No	: (2011 - 1025455)
Capacity and Head	: (25 m ³ /h - 19 m)

H3- If you prefer to have spare parts in your stock, we recommend you to have the following quantities for a two year operation depending on the number of same type of pumps.

Part No	Part Name	Number of Pump in the syste							
		2	3	4	5	6-7	8-9	+10	
49	Rubber Bellows	1	1	2	2	3	4	% 50	
50	Impeller	1	1	2	2	3	4	% 50	
57	Rotating Cutter	1	1	2	2	3	4	% 50	
59	Fixed Cutter	1	1	2	2	3	4	% 50	
61	Shaft with Rotor	-	-	1	1	1	2	% 20	
65	Impeller Nut	1	1	2	2	3	4	% 50	
90	Wound Rotor	-	-	1	1	1	2	% 20	
200	Bottom Bearing	1	2	2	3	4	5	% 60	
201	Top Bearing	1	2	2	3	4	5	% 60	
220	Retaining Ring	1	2	2	3	4	5	% 60	
221	Retaining Ring	1	2	2	3	4	5	% 60	
222	Retaining Ring	1	2	2	3	4	5	% 60	
405	Mechanical Seal	2	3	4	5	7	9	% 100	
410	Oil Lip Seal	4	6	8	12	14	18	% 100	
420	O-Ring (Top Cover)	1	2	2	3	4	5	% 60	
421	O-Ring (Oil Plug)	6	9	12	15	21	27	% 100	
423	O-Ring (Socket)	1	2	2	3	4	5	% 60	

Table 3. Recommended spare parts and their quantities for two years operation

I- FAULTS AND CAUSES

FAULTS	POSSIBLE CAUSES	REMEDIES
Motor doesn't run	There is no power supply to control panel.	Check the mains input on the panel. Adjust the cable connection.
	One or more fuses cut down.	Fit fuses of the correct type.
	Energy and control cable is broken.	Change the energy and control cables.
	PCST3-V2 relay is off.	Detect and adjust the fault which is shown on PCST3-V2 relay.
There is no discharge	Impeller is stuck (It is blocked).	Clean inside of the pump.
	Discharge (or riser) pipe is clogged.	Clean inside of the discharge pipe.
	Pump discharge head is insufficient for pumping.	Check the system design values.
	There is not enough water in the sump.	Check the water input to the sump.
Low pump capacity	Reverse direction of rotation.	Interchange the power cable of any two phases on the control panel.
	There is partial clogging at discharge pipe system.	Clean inside of the discharge pipe.
	A partial clogging happens in the impeller or in the pump casing.	Clean inside of the pump.
	Impeller had worn out.	Change the impeller.
Over heat circuit of PCST3-V2 relay stops the motor frequently.	The level of the stop float switch is too low. Motor runs dry.	Increase the level of the stop float switch.
	Manometric head is too low.	Adjust the flow control valve according to the manometric head stated on the name plate.
	Pumped liquid is very dense or its specific gravity is high.	Adjust the flow control valve according to the current stated on the name plate.
Water leakage circuit of PCST3-V2 relay stops the pump	Energy and control cable has been crushed or torn.	Change the power cable.

J- DISASSEMBLY DRAWINGS

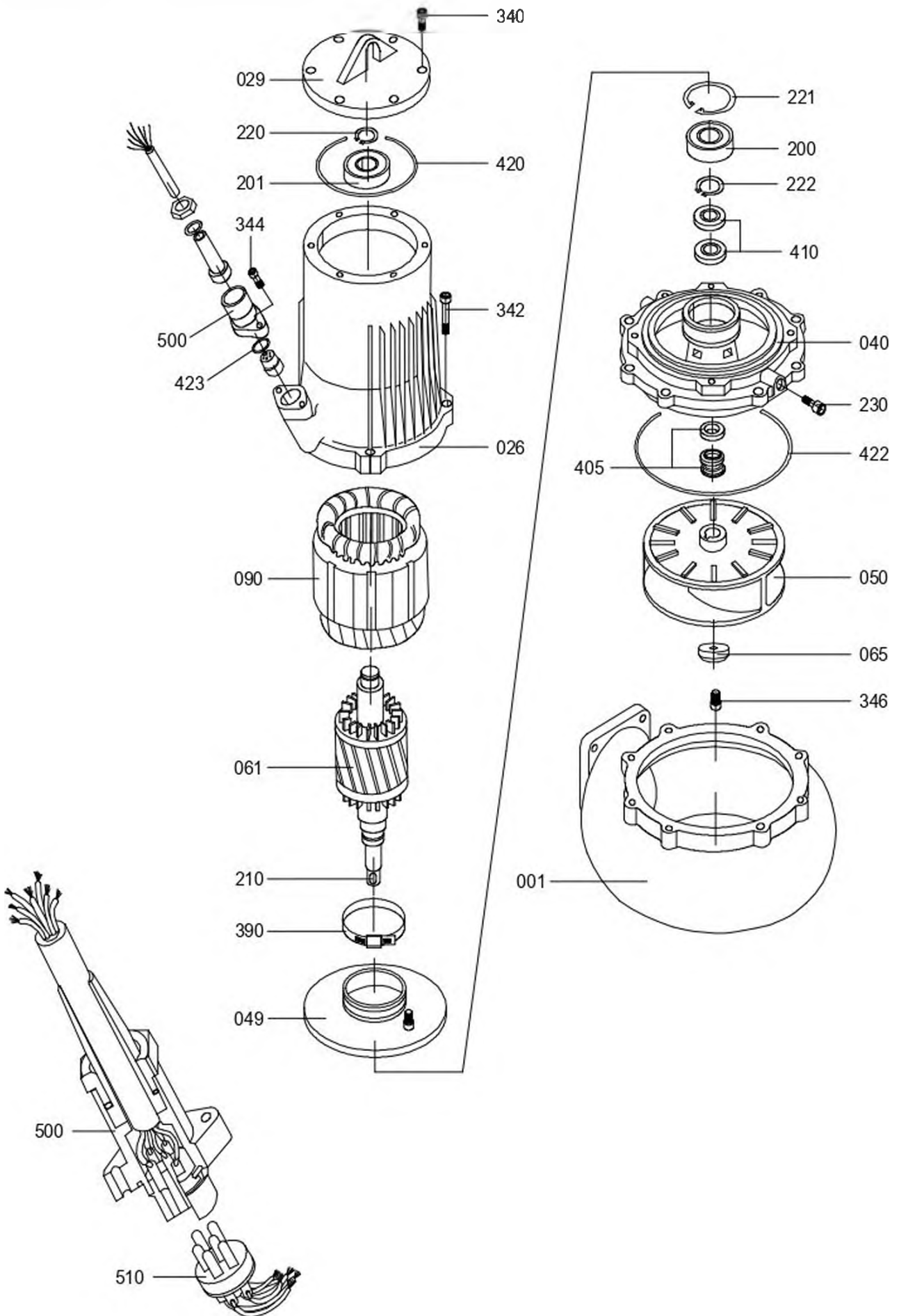

Алматы (7273)495-231
Ангарск (3955)60-70-56
Архангельск (8182)63-90-72
Астрахань (8512)99-46-04
Барнаул (3852)73-04-60
Белгород (4722)40-23-64
Благовещенск (4162)22-76-07
Брянск (4832)59-03-52
Владивосток (423)249-28-31
Владикавказ (8672)28-90-48
Владимир (4922)49-43-18
Волгоград (844)278-03-48
Вологда (8172)26-41-59
Воронеж (473)204-51-73
Екатеринбург (343)384-55-89
Россия +7(495)268-04-70

Иваново (4932)77-34-06
Ижевск (3412)26-03-58
Иркутск (395)279-98-46
Казань (843)206-01-48
Калининград (4012)72-03-81
Калуга (4842)92-23-67
Кемерово (3842)65-04-62
Киров (8332)68-02-04
Коломна (4966)23-41-49
Кострома (4942)77-07-48
Краснодар (861)203-40-90
Красноярск (391)204-63-61
Курск (4712)77-13-04
Курган (3522)50-90-47
Липецк (4742)52-20-81
Казахстан +7(7172)727-132

Магнитогорск (3519)55-03-13
Москва (495)268-04-70
Мурманск (8152)59-64-93
Набережные Челны (8552)20-53-41
Нижегород (831)429-08-12
Новокузнецк (3843)20-46-81
Ноябрьск (3496)41-32-12
Новосибирск (383)227-86-73
Омск (3812)21-46-40
Орел (4862)44-53-42
Оренбург (3532)37-68-04
Пенза (8412)22-31-16
Петрозаводск (8142)55-98-37
Псков (8112)59-10-37
Пермь (342)205-81-47
Киргизия +996(312)96-26-47

Ростов-на-Дону (863)308-18-15
Рязань (4912)46-61-64
Самара (846)206-03-16
Саранск (8342)22-96-24
Санкт-Петербург (812)309-46-40
Саратов (845)249-38-78
Севастополь (8692)22-31-93
Симферополь (3652)67-13-56
Смоленск (4812)29-41-54
Сочи (862)225-72-31
Ставрополь (8652)20-65-13
Сургут (3462)77-98-35
Сыктывкар (8212)25-95-17
Тамбов (4752)50-40-97
Тверь (4822)63-31-35

Тольятти (8482)63-91-07
Томск (3822)98-41-53
Тула (4872)33-79-87
Тюмень (3452)66-21-18
Ульяновск (8422)24-23-59
Улан-Удэ (3012)59-97-51
Уфа (347)229-48-12
Хабаровск (4212)92-98-04
Чебоксары (8352)28-53-07
Челябинск (351)202-03-61
Череповец (8202)49-02-64
Чита (3022)38-34-83
Якутск (4112)23-90-97
Ярославль (4852)69-52-93

vpo@nt-rt.ru || <https://vestapomp.nt-rt.ru/>